



Product Catalog

Packaged Rooftop Air Conditioners Foundation™ Cooling and Gas/ Electric

3 to 5 Tons, 60Hz





Introduction

Packaged Rooftop Air Conditioners



Through the years, Trane has designed and developed the most complete line of Packaged Rooftop products available in the market today.

Trane customers demanded a product that provided exceptional reliability, was easy to install, and was competitively priced. Trane listened and is proud to introduce the new Trane Foundation™ Light Commercial rooftop unit.

With Foundation, Trane continues to provide the highest standards in quality and reliability, comfort, performance, and ease of installation.

Copyright

This document and the information in it are the property of Trane, and may not be used or reproduced in whole or in part without written permission. Trane reserves the right to revise this publication at any time, and to make changes to its content without obligation to notify any person of such revision or change.

Trademarks

Trane and the Trane logo, Foundation, and Frostat are trademarks of Trane in the United States and other countries. All trademarks referenced in this document are the trademarks of their respective owners.

Revision History

- Updated 2-inch MERV 13 throwaway filters information in Features and Benefits, Electrical Data and Mechanical Specifications chapters.
- Running edits.



Table of Contents

Features and Benefits	4
Standard and Optional Features at a Glance	4
Outstanding Standard Features	5
Variety of Options	8
Other Benefits	10
Application Considerations	12
Selection Procedure	13
Cooling Capacity	13
Heating Capacity	14
Air Delivery Selection	14
Model Number Description	15
General Data	16
Performance Data	18
Controls	42
Economizer Controls	42
Thermostats	42
Electrical Data	43
Jobsite Connections	47
Dimensional Data	48
Weights	52
Mechanical Specifications	54



Features and Benefits

Foundation™ has features and benefits that make it first class in the light commercial rooftop market. Designed with input from field contractors and technicians, its convertible airflow and ease of installation are outstanding.

Standard and Optional Features at a Glance

Standard Features

- 2-inch throwaway filters
- 5kA SCCR (Short Circuit Current Rating)
- 5 year Limited Compressor Warranty
- 5 year Limited Heat Exchanger
- 1 year Limited Parts Warranty
- Belt Drive Motors
- Cleanable Condensate Drain Pan
- Colored and Numbered Wiring
- Convertible Airflow
- Cooling to 45°F
- Discharge Line Thermostat
- Electromechanical Controls
- Easy Access Low Voltage Terminal Board (LTB)
- Foil-Faced and Edge Captured Insulation
- High Pressure Cutout
- Liquid Line Refrigerant Drier
- Locking Safety Device with Anti-Short Cycle Timer
- Microchannel Type Condenser and Evaporator Coils
- Operating Charge of R-410A
- Phase Monitor
- Provisions for Through-the-Base Electrical
- Quick Access Panels
- Quick Adjust Fan Motor Mounting Plate
- Single Point Power
- Single Side Service
- Standardized Components
- Tubular Aluminized Steel heat Exchanger

Factory Installed Options

- Complete Coat™ Microchannel Condenser Coil
- Stainless Steel Heat Exchanger with 10 Year Warranty

Factory or Field Installed Options

- Barometric Relief¹ (Downflow Low Leak Economizer Only)
- Condensate Overflow Switch
- Economizer (Downflow)¹
- Electric Heaters
- Low Leak Economizer with Fault Detection and Diagnostics and 5 Year Limited Warranty - Downflow
- Manual Outside Air Dampers
- Motorized Outside Air Dampers
- Oversized Motor
- Reference or Comparative Enthalpy Economizer

- Through the Base Electrical Access
- Through the Base Gas Piping
- Unit Mounted Non-Fused Disconnect Switch²
- 2-inch MERV 13 throwaway Filters

Field Installed Options

- Barometric Relief (Standard and Low Leak Economizer, Downflow and Horizontal Configuration)
- Crankcase Heater
- Demand Control Ventilation with CO₂ Sensor
- Economizer (Horizontal)
- Froststat™
- Low Ambient Kit
- Low Leak Economizer with Fault Detection and Diagnostics and 5 Year Limited Warranty - Horizontal
- LP Conversion Kit
- Powered Exhaust
- Remote Potentiometer
- Roof Curb
- Thermostat
- Tool-less Hail Guard

Note: Explanation of Notes located in *"Model Number Description," p. 15.*

Other Benefits

- Cabinet Design Ensures Water Integrity
- Convertible Airflow - Downflow to Horizontal Airflow Configuration
- Ease of Service, Installation and Maintenance
- Mixed Model Build Enables "Fastest in the Industry" Ship Cycle Times
- Rigorous Testing
- Unmatched Product Support

Outstanding Standard Features

Colored and Numbered Wiring

Save time and money tracing wires and diagnosing the unit.

Compressor

Foundation™ contains the best compressor technology available to achieve the highest possible performance.

Controls—Electromechanical

This 24-volt control includes the control transformer and contactor pressure lugs for power wiring.

Features and Benefits

Convertible Units



Foundation 3-5 tons units ship in downflow configuration. Their convertible design makes it easy to convert them to a horizontal airflow configuration without any kit or tool.

Discharge Line Thermostat

A bi-metal element discharge line thermostats installed as a standard feature on the discharge line of each system. This standard feature provides extra protection to the compressors against high discharge temperatures in case of loss of charge, extremely high ambient and other conditions which could drive the discharge temperature higher.

Efficiency

Product efficiencies meet the requirements of ASHRAE 90.1 - 2016.

Easy Access Low Voltage Terminal Board

Foundation™ Low Voltage Terminal Board is mounted outside the main electrical control cabinet. It is extremely easy to locate and attach the thermostat control wiring and also test operation of all unit functions. This is another cost and time saving installation feature.

Foil Faced Insulation

All panels in the evaporator section of the unit have cleanable foil-faced insulation. All edges are either captured or sealed to ensure no insulation fibers get into the airstream.

Heat Exchanger

The cabinet features a tubular heat exchanger in low and medium heat capacities. The heat exchanger is fabricated using aluminized steel burners and corrosion-resistant aluminized steel tubes as standard on all models. As part of the heat exchanger assembly, an induced draft blower is used to pull the gas mixture through the burner tubes. A direct spark ignition system, which doubles as a safety device to prove the flame, is used to ignite the gas mixture.

Locking Safety Device with Anti-Short Cycle Timer

This device monitors compressor safety switch trips to prevent short cycling, protecting the compressor. A manual reset is required after a fourth safety switch trip within a 6 hour period.

Low Ambient Cooling

All Foundation units have cooling capabilities down to 45°F as standard.

Low Voltage Connections

The wiring of the low voltage connections to the unit and the thermostat is as simple as R-R, G-G, Y-Y, and W-W. This simplified system makes it easy for the installer to wire.

Microchannel Coils

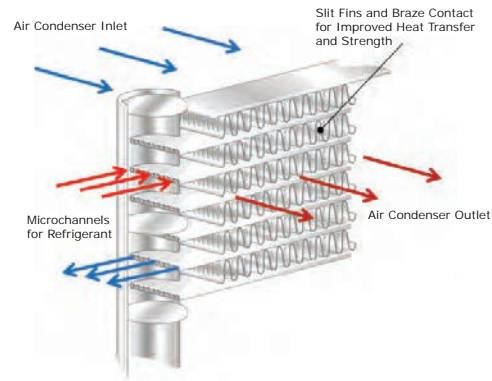

Microchannel coils are all-aluminum coils with fully-brazed construction. This design reduces risk of leaks and provides increased coil rigidity — making them more rugged on the jobsite. Their flat streamlined tubes with small ports and metallurgical tube-to-fin bond allow for exceptional heat transfer.

Microchannel all-aluminum construction provides several additional benefits:

- Light weight (simplifies coil handling)
- Easy to recycle
- Minimize galvanic corrosion

Motors

All indoor fan motors are belt drive as standard.

Pressure Cutouts

Low and high pressure cutouts are standard on all Foundation™ models.

Phase Monitor

Foundation features a three-phase line monitor module that protects against phase loss, phase reversal and phase unbalance. It is intended to protect compressors from reverse rotation. It has an operating input voltage range of 190–600 Vac, and LED indicators for ON and FAULT. There are no field adjustments and the module will automatically reset from a fault condition.

Quick-Access Panels

Remove four or less screws for access to the standardized internal components and wiring.

Quick-Adjust Fan Motor Mounting Plate

With the quick-adjust slider plate, the belt and sheaves can be quickly adjusted without moving the mounted fan motor. This results in reduced time spent on routine maintenance.

Single Point Power

A single electrical connection powers the unit and all on-board options.

Single Side Service

Single side service is standard on all units.

Sloped Drain Pans

Every Foundation™ unit has a non-corrosive, sloped drain pan made of rigid PVC - standard on all units - that is removable for easy cleaning.

Standardized Components

Components are placed in the same location on all Foundation units. Familiarize yourself with one Foundation and you are familiar with every Foundation. Due to standardized components throughout the Foundation line, contractors/owners can stock fewer parts.



Variety of Options¹

Factory Installed Options

Complete Coat™ Condenser Coil

The cathodic epoxy type electrodisposition coating is formulated for high edge build to a number of different types of heat exchangers. The coating is selected to provide excellent resistance and durability to corrosive effects of alkalies, acids, alcohols, petroleum, seawater, salt air, and corrosive environments.

Stainless Steel Heat Exchanger

The optional stainless steel heat exchanger is constructed of 409 stainless steel tubes and 439 stainless steel burners. It is resistant to corrosion and oxidation and easy to clean. The high strength to weight ratio allows for high ventilation rates with gas units and comes standard with a modulating gas heat option. With this option, a 10-year stainless steel heat exchanger warranty is standard.

Factory or Field Installed Options

Barometric Relief

Barometric relief is an unpowered means of relieving excess building pressure.

Note: *The factory installed barometric relief is for downflow low leak economizer units only.*

Condensate Overflow Switch

A condensate overflow switch is available to shut the unit down in the event that the condensate drain line becomes clogged. This option protects the unit from water overflowing from the drain pan and entering the base of the units.

Disconnect Switch

This accessory can be utilized as a convenient way to stock standard product without a disconnect and have the ability to use the through the base/disconnect offering. The standard disconnect is non-fused, 3-pole, case molded switch.

Economizer - Downflow

Economizers are equipped with either dry bulb, reference, or comparative enthalpy sensing. These economizers provide free cooling as the outdoor temperature and/or humidity decreases. Correctly installed, they offer valuable energy savings. Factory-installed economizers save time and ensure proper installation.

Note: *Factory-installed economizers require some field set-up.*

Electric Heat

Electric heat is available as a factory or field installed option.

Note: *For EBC036-060 cooling only units.*

Low Leak Economizer with Fault Detection and Diagnostics - Downflow

This economizer meets the damper leakage requirements for ASHRAE 90.1, IECC, and California Title 24 standards (3 cfm/ft² at 1.0 in. w.g. for outside air dampers and 4 cfm/ft² for return dampers). Also, Fault Detection and Diagnostic information per California Title 24 is provided with this option. Barometric relief must be field installed with this option. Horizontal airflow configurations may only be field installed.

¹ Refer to "Model Number Description," p. 15 for option availability.

Manual Outside Air Damper

A 0–50 percent manual air damper is available.

Motorized Outside Air Damper

A 0–50 percent motorized outside air dampers is available.

Oversized Motors

Factory or field installed oversized motors are available for high static applications.

Reference or Comparative Enthalpy

Measures and communicates humidity while maximizing comfort control.

Through-the-Base Electrical Utility Access

An electrical service entrance shall be provided allowing access for both control and main power connections inside the curb and through the base of the unit. This option will allow for field installation of liquid-tight conduit and an external field installed disconnect switch.

Factory provided through the base openings simplify wiring and piping. Because these utility openings frequently minimize the number of roof penetrations, the integrity of roofing materials is enhanced.

Through-the-Base Gas Piping (Gas Heat Units Only)

This option shall have all piping necessary including, black steel, manual gas shut-off valve, elbows, and union. This assembly will require minor field labor to install.

Field Installed Options**Barometric Relief**

Designed to be used on downflow and horizontal configuration for both standard and low leak economizer units, barometric relief is an unpowered means of relieving excess building pressure.

CO₂ Sensor - Demand Control Ventilation (DCV)

Demand-controlled ventilation (DCV) is a control strategy that responds to the actual demand (need) for ventilation by regulating the rate at which the HVAC system brings outdoor air into the building. A CO₂ sensor measures the concentration (parts per million, ppm) of CO₂ in the air. As the CO₂ concentration changes, the outside air damper modulates to meet the current ventilation needs of the zone. DCV is a passive system; direct control of the indoor fan is not possible with standard or low leak economizers. The CO₂ sensor kit is available as a field installed accessory.

Crankcase Heaters

These band heaters provide improved compressor reliability by warming the oil to prevent migration during off-cycles or low ambient conditions.

Economizer - Horizontal

Economizers are equipped with either dry bulb or reference or comparative enthalpy sensing. These economizers provide free cooling as the outdoor temperature and/or humidity decreases. Correctly installed, they offer a valuable energy savings.

Frostat™

This switch, attached to the tube of the evaporator coil, monitors coil temperature to prevent evaporator icing and protect the compressor. Recommended for applications with low leaving air temperatures, low airflow and/or high latent load applications.



Features and Benefits

Low Ambient Kit

Allows system to operate in cooling below 45 degree by maintaining head pressure by cycling the outdoor fan motor allowing safe system operation without indoor coil icing.

Low Leak Economizer with Fault Detection and Diagnostics - Horizontal

This economizer meets the damper leakage requirements for ASHRAE 90.1, IECC, and California Title 24 standards (3 cfm/ft² at 1.0 in. w.g. for outside air dampers and 4 cfm/ft² for return dampers). Also, Fault Detection and Diagnostic information per California Title 24 is provided with this option. Barometric relief must be field installed with this option. Horizontal airflow configurations may only be field installed.

LP Conversion Kit

Provided for field conversion of gas heat units from natural gas to propane.

Power Exhaust

This option is available on downflow units and provides exhaust of the return air, when using a downflow economizer, to maintain proper building pressurization. This is an excellent option for relieving most building overpressurization problems.

Remote Potentiometer

When installed in the economizer control circuitry, this accessory provides a method to remotely adjust the minimum damper position.

Roof Curbs

Available for downflow units.

Thermostats

Available in programmable and non-programmable.

Tool-less Hail Guards

Tool-less, hail protection quality coil guards shall be field-installed for condenser coil protection. This option protects the condenser coil from vandalism and/or hail damage.

Other Benefits

Cabinet Integrity

For added water integrity, Foundation has a raised 1-1/8" lip around the supply and return of the downflow units to prevent water from blowing into the ductwork.

Easy to Install, Service and Maintain

Because today's owners are very cost-conscious when it comes to service and maintenance, Foundation was designed with direct input from service contractors. This valuable information helped to design a product that would get the service technician off the job quicker and save the owner money. Foundation does this by offering outstanding standard features enhanced by a variety of factory and field installed options, multiple control options, rigorously tested proven designs and superior product and technical support.

Outstanding Adaptability

The Foundation 3-5 Tons units match the footprint of specific Carrier WeatherMaker units.

Rigorous Testing

All of Foundation's designs were rigorously rain tested at the factory to ensure water integrity. Foundation units incorporate either a one piece top or the Trane-Tite-Top (T3). Each part of the top

overlaps in such a way that water cannot leak into the unit. These overlapped edges are gasketed and sealed to ensure superior water integrity.

Actual shipping tests were performed to determine packaging requirements. Units were test shipped around the country to determine the best packaging. Factory shake and drop tests were used as part of the package design process to help assure that the unit arrives at the job site in top condition.

Rigging tests include lifting a unit into the air and letting it drop one foot, assuring that the lifting lugs and rails hold up under stress. For the microchannel coils, the supplier will perform the leak check at 450 psig. The completely assembled refrigerant system is leak tested at a minimum of 225 psig with a refrigerant and nitrogen mixture.

All parts are inspected at the point of final assembly. Sub-standard parts are identified and rejected immediately. Every unit receives a 100% unit run test before leaving the production line to make sure it lives up to rigorous Trane requirements.

Unmatched Support

Trane Sales Representatives are a Support Group that can assist you with:

- Product
- Application
- Service
- Training
- Special Applications
- Specifications
- Computer Programs and much more



Application Considerations

Application of this product should be within the cataloged airflow and cooling considerations.

Barometric Relief

This product line offers an optional barometric relief damper for use in conjunction with economizer option. This accessory consists of gravity dampers which open with increased pressure. As building pressure increases, the pressure in the unit return air section also increases, opening the dampers and relieving the conditioned space.

Notes:

- *The effectiveness of barometric relief damper during economizing operation is system related.*
- *Pressure drop of the return air system should be considered to control building pressurization.*

Clearance Requirements

The recommended clearances identified with unit dimensions should be maintained to ensure adequate serviceability, maximum capacity and peak operating efficiency. Actual clearances which appear inadequate should be reviewed with local Trane sales personnel.

Complete Coat™ Microchannel Condenser Coil

The cathodic epoxy type electrodisposition coating is formulated for high edge build to a number of different types of heat exchangers. The coating is selected to provide excellent resistance and durability to corrosive effects of alkalis, acids, alcohols, petroleum, seawater, salt air, and corrosive environments. This coating shall be available on microchannel condenser coils.

Condensate Trap

The evaporator is a draw-through configuration. A trap must be field provided prior to start-up on the cooling cycle.

Heating Operation

The heat exchanger is manufactured with aluminized steel. To prevent condensation within the heat exchanger, do not exceed 50 percent outside air or a minimum mixed air temperature of 40°F.

Optional Stainless Steel Heat Exchanger

The optional stainless steel heat exchanger is manufactured with 409 stainless steel. To prevent corrosion and prolong heat exchanger reliability, the minimum mixed air temperature allowed across the heat exchanger is 40°F. The stainless steel heat exchanger option is an excellent option that compliments the dehumidification package and is used in conjunction with the modulating heat option. Whenever high outside air or outside applications exist, these options should be utilized.

Low Ambient Cooling

The Foundation line features low ambient cooling down to 45°F. The following options need to be included/considered when low ambient applications are required: continuous fan operation, crankcase heaters, or low pressure bypass timer. Contact your local Trane Representative for more assistance with low ambient cooling applications.

Unit Pitch

These units have sloped condensate drain pans. Units must be installed level. Any unit slope must be toward access side of the unit.



Selection Procedure

Cooling Capacity

Note: Cooling Capacity Procedure is the same for cooling (E) and gas/electric (G).

Step 1

Calculate the building's total and sensible cooling loads at design conditions. Use the following calculation methods or any other standard accepted method. Factors used in unit selection:

- Total Cooling Load: 61MBh
- Sensible Cooling Load: 45 MBh
- Airflow: 2000 cfm
- Electrical Characteristics: 460/60/3
- Summer Design Conditions: Entering Evaporator Coil: 80 DB, 67 WB Outdoor Ambient: 95 DB
- External Static Pressure: 0.36 in. wg
- Rooftop: downflow configuration
- Accessories:
 - Roof curb
 - Economizer
 - Electric Heat

Step 2

As a starting point, a rough determination must be made of the size of the unit. The final selection will be made after examining the performance at the given conditions. Divide the total cooling load by nominal Btu/h per ton (12 MBh per ton); then round up to the nearest unit size.

$$61\text{MBh} / 12 \text{ MBh} = 5.0 \text{ tons}$$

Step 3

Table 5, p. 20 shows that a EBC060A has a **gross** cooling capacity of 60.8 MBh and 47.8 MBh sensible capacity at 2000 cfm and 95 DB outdoor ambient with 80 DB, 67 WB air entering the evaporator.

To Find Capacity at Intermediate Conditions Not in the Table

When the design conditions are between values that are identified in the capacity table, interpolation is required to approximate the capacity.

Note: Extrapolation outside of the table conditions is not recommended.

Step 4

In order to select the correct unit which meets the building's requirements, the fan motor heat must be deducted from the gross cooling capacity. The amount of heat that the fan motor generates is dependent on the effort by the motor—cfm and static pressure. To determine the total unit static pressure you add the external static pressure to the additional static related by the added features:

External Static Duct System: 0.36 in. wg

Standard Filter from Table 26, p. 39: 0.06 in. wg

Economizer from Table 26, p. 39 (100% Return Air): 0.07 in. wg

Electric Heater Size kW from Table 26, p. 39: 0.07 in. wg

(Reference "Heating Capacity," p. 14 for determination of heater size.) No additional static add for gas/heat exchanger.

Selection Procedure

Total Static Pressure: 0.56 in. wg

Note: The Evaporator Fan Performance [Table 18, p. 33](#) has already accounted for the pressure drop for standard filters and wet coils (see note below that table). Therefore, the actual total static pressure is $0.56 - 0.06$ (from [Table 26, p. 39](#)) = 0.50 in. wg.

With 2000 cfm and 0.50 wg.

[Table 18, p. 33](#) shows 0.81 bhp for this unit. Note below the table gives a formula to calculate Fan Motor Heat: $2.8328 \times \text{Fan bhp} + 0.4714$.

$$2.8328 \times 0.81 + 0.4714 = 2.76 \text{ MBh}$$

Now subtract the fan motor heat from the gross cooling capacity of the unit:

Net Total Cooling Capacity = $60.8 \text{ MBh} - 2.76 = 58.04 \text{ MBh}$.

Net Sensible Cooling Capacity = $47.8 \text{ MBh} - 2.76 = 45.04 \text{ MBh}$.

Step 5

If the performance will not meet the required load of the building—total or sensible cooling load, try a selection at the next higher size unit.

Heating Capacity

Note: Heating capacity procedures DIFFER for cooling (E) and gas/electric (G) units.

Step 1

Calculate the building heating load.

Step 2

Size the system heating capacity to match the calculated building heating load.

The electric heat accessory capacities are listed in [Table 28, p. 40](#). From the table, a 10 kW heater will deliver 34.14 MBh at 480 volts. In order to determine capacity at 460 volts, the heater voltage correction factor from [Table 29, p. 41](#) must be used. Therefore, $34.14 \text{ MBh} \times 0.92$ (voltage correction factor) = 31.41 MBh.

Air Delivery Selection

Note: Air Delivery procedures is the same for cooling (E) and gas/electric (G) units.

External static duct pressure drop through the air distribution system has been calculated to be 0.36 inches of water. From [Table 26, p. 39](#) static pressure drop through the economizer is 0.07 and the 10kW heater is 0.07 inches of water.

Therefore the total static pressure is $0.36 + 0.07 + 0.07 = 0.50$ inches.

Enter [Table 18, p. 33](#) for a EBC060A4 at 2000 cfm and 0.50 static pressure. The standard motor at 948 rpm will give the desired airflow at a rated bhp of 0.81.



Model Number Description

Digit 1 – Unit Type

- E = Packaged Cooling, Electric Heat
- G = Packaged Cooling, Gas Heat

Digit 2 – Efficiency

- B = ASHRAE 90.1 - 2016

Digit 3 – Airflow Configuration

- C = Convertible

Digit 4, 5, 6 – Nominal Gross Cooling Capacity (MBh)

- 036 = 3 Tons
- 048 = 4 Tons
- 060 = 5 Tons

Digit 7 – Major Design Sequence

- A

Digit 8 – Voltage Selection

- 3 = 208-230/60/3
- 4 = 460/60/3
- W = 575/60/3
- K = 380/60/3^{6, 7}

Digit 9 – Unit Controls

- E = Electromechanical

Digit 10 – Heating Capacity

Note: (Applicable to Digit 1 = E models only)

- 0 = No Heat
- A = 4.7 kW Electric Heat
- B = 7.5 kW Electric Heat
- C = 10 kW Electric Heat
- D = 14.4 kW Electric Heat
- E = 20 kW Electric Heat
- F = 25 kW Electric Heat

Note: (Applicable to Digit 1 = G models only)

- L = Gas Heat - Low
- M = Gas Heat - Medium
- X = Gas Heat - SS Ht Ex - Low
- Y = Gas Heat - SS Ht Ex - Medium

Digit 11 – Minor Design Sequence

Digit 12, 13 – Service Sequence

- 00 = None

Digit 14 – Fresh Air Selection³

- 0 = No Fresh Air
- A = Manual Outside Air Damper 0-50%
- B = Motorized Outside Air Damper 0-50%
- C = Economizer, Dry Bulb 0-100% without Barometric Relief⁴
- E = Economizer, Reference Enthalpy 0-100% without Barometric Relief⁴
- G = Economizer, Comparative Enthalpy 0-100% without Barometric Relief⁴
- J = Downflow Low Leak Economizer, Dry Bulb w/o Barometric Relief⁴

- L = Downflow Low Leak Economizer, Reference Enthalpy w/o Barometric Relief⁴

- N = Downflow Low Leak Economizer, Comparative Enthalpy w/o Barometric Relief⁴

Digit 15 – Supply Fan/Drive Type/Motor

- 0 = Standard Motor
- 1 = Oversized Motor

Digit 16 – Not Used

Digit 17 – Condenser Coil Protection

- 0 = Standard Coil
- 4 = CompleteCoat™ Condenser Coil

Digit 18 – Through The Base Provisions

Note: Applicable to Digit 1, E models.

- 0 = No Through The Base Provisions
- A = Through The Base Electric

Note: Applicable to Digit 1, G models only.

- 0 = No Through The Base Provisions
- A = Through-The-Base Electric
- B = Through-The-Base Gas¹
- C = Through-The-Base Electric/Gas

Digit 19 – Disconnect Switch

- 0 = No Disconnect
- 1 = Unit Mounted Non-Fused Disconnect Switch²

Digit 20– Not Used

Digit 21– Not Used

Digit 22– Not Used

Digit 23– Not Used

Digit 24– Not Used

Digit 25 - System Monitoring Controls

- 0 = No Monitoring Controls
- A = Condensate Drain Pan Overflow Switch

Digit 26 - System Monitoring Controls

- 0 = No Economizer Fault Detection and Diagnostics (FDD)
- B = Economizer Fault Detection and Diagnostics (FDD)⁵

services for estimated production cycle.

4. Factory installed economizers only available in downflow configuration.
5. Fault Detection and Diagnostics (FDD) is available on Low Leak Economizers only.
6. Available on Digit 1 = E units only.
7. Unit will operate reliably at 400V.

Model Number Notes

1. Some field set up required.
2. Must be ordered with Through-the-Base Electrical option.
3. All Factory Installed Options are Built-to-Order. Check order



General Data

Table 1. General data – 3-5 tons

	3 Tons	4 Tons	5 Tons
	E/GBC036	E/GBC048	E/GBC060
Cooling Performance^(a)			
Gross Cooling Capacity	37,000	51,100	59,000
EER ^(b)	12	12	12
Nominal Airflow CFM / AHRI Rated CFM	1200 / 1200	1600 / 1600	2000 / 1600
AHRI Net Cooling Capacity	36,000	49,500	57,500
Seasonal Energy Efficiency Ratio (SEER) ^(c)	14	14	14
System Power (kW)	3.00	4.13	4.79
Compressor			
Number/Type	1 / Scroll	1 / Scroll	1 / Scroll
Sound			
Outdoor Sound Rating (dBA) ^(d)	79	80	81
Outdoor Coil			
Type	Microchannel	Microchannel	Microchannel
Coil Width (in.)	0.63	0.63	1.0
Face Area (sq. ft.)	11.33	13.46	15.92
Rows/FPI	1 / 23	1 / 23	1 / 23
Indoor Coil			
Type	Microchannel	Microchannel	Microchannel
Coil Width (in.)	0.63	0.63	0.81
Face Area (sq. ft.)	6.44	6.44	6.44
Rows/FPI	2 / 16	2 / 16	2 / 16
Refrigerant Control	Thermal Expansion Valve	Thermal Expansion Valve	Thermal Expansion Valve
Drain Connection Number/Size (in.)	1 / 3/4-14 NPT female	1 / 3/4-14 NPT female	1 / 3/4-14 NPT female
Outdoor Fan			
Type	Propeller	Propeller	Propeller
Number Used/Diameter (in.)	1 / 23	1 / 23	1 / 23
Drive Type/No. Speeds	Direct / 1	Direct / 1	Direct / 1
cfm	4,000	4,000	4,000
Number Motors/hp	1 / 0.33	1 / 0.33	1 / 0.33
Motor rpm	1100	1100	1100
Indoor Fan			
Type	FC Centrifugal	FC Centrifugal	FC Centrifugal
Number Used/Diameter (in.)	1 / 11x11	1 / 11x11	1 / 11x11
Drive Type/No. Speeds	Belt / 1	Belt / 1	Belt / 1
Number Motors	1	1	1
Motor hp (Standard/Oversized)	1.0 / 2.0	1.0 / 2.0	1.0 / 2.0
Motor rpm (Standard/Oversized)	1750 / 1750	1750 / 1750	1750 / 1750
Motor Frame Size (Standard/Oversized)	56 / 56	56 / 56	56 / 56
Filters			
Type Furnished	Throwaway	Throwaway	Throwaway
Number Size Recommended	(4) 16x16x2	(4) 16x16x2	(4) 16x16x2
Refrigerant Charge (Pounds of R-410A)^(e)			
Circuit 1	3.5	3.7	5.0

(a) Cooling Performance is rated at 95°F ambient, 80°F entering dry bulb, 67°F entering wet bulb. Gross capacity does not include the effect of fan motor heat. ARI capacity is net and includes the effect of fan motor heat. Units are suitable for operation to ±20% of nominal cfm. Certified in accordance with the Unitary Air-Conditioner Equipment Certification Program, which is based on AHRI Standard 210/240.

(b) EER is rated at AHRI conditions and in accordance with AHRI Standard 210/240.

(c) Seasonal Energy Efficiency Ratio (SEER) is rated in accordance with AHRI standard 210/240 and DOE test procedures.

(d) Outdoor Sound Rating shown is tested in accordance with AHRI Standard 270.

(e) Refrigerant charge is an approximate value. For a more precise value, see unit nameplate and service instructions.

Table 2. General data—heating performance – 3-5 tons

	Heating Performance ^(a)					
	3 Tons		4 Tons		5 Tons	
Heating Models	Low	Medium	Low	Medium	Low	Medium
Heating Input (Btu/h)	72,000	100,000	72,000	115,000	72,000	115,000
1st Stage (Btu)		80,000		92,000		92,000
Heating Output (Btu/h)	57,600	80,000	57,600	92,000	57,600	92,000
1st Stage (Btu)		64,000		73,600		73,600
Steady State Efficiency%	80%	80%	80%	80%	80%	80%
No. Burners	2	3	2	3	2	3
No. Stages	1	2	1	2	1	2
Gas Supply Line Pressure (in. wc)	4.0 / 14.0	4.0 / 14.0	4.0 / 14.0	4.0 / 14.0	4.0 / 14.0	4.0 / 14.0
Natural Gas (minimum/maximum)	11.0 / 14.0	11.0 / 14.0	11.0 / 14.0	11.0 / 14.0	11.0 / 14.0	11.0 / 14.0
Gas Connection Pipe Size (in.)	1/2"	1/2"	1/2"	1/2"	1/2"	1/2"

(a) Heating Performance limit settings and rating data were established and approved under laboratory test conditions using American National Standards Institute standards (ANSI). Ratings shown are for elevations up to 2000 feet. For elevations above 2000 feet, ratings should be reduced at the rate of 4% for each 1000 feet above sea level.



Performance Data

Table 3. Gross cooling capacities 3 tons - E/GBC036A3,4,W,K

		Ambient Temperature																	
		85						95						105					
Air	Ent	Entering Wet Bulb																	
Flow	DB	61		67		73		61		67		73		61		67		73	
cfm	(°F)	MBh	SHC	MBh	SHC	MBh	SHC	MBh	SHC	MBh	SHC	MBh	SHC	MBh	SHC	MBh	SHC	MBh	SHC
960	75	33.5	27.1	37.8	21.4	42.2	14.6	31.6	26.1	35.7	20.4	39.7	14.3	29.6	25.0	33.4	19.3	36.9	13.2
	80	33.6	31.3	37.8	26.3	42.3	20.3	31.7	30.5	35.7	25.3	39.8	19.3	29.8	29.6	33.4	24.3	37.0	18.2
	85	34.8	34.8	37.8	31.2	42.3	25.3	33.3	33.3	35.7	30.2	39.8	24.2	31.4	31.4	33.4	29.1	37.0	23.1
	90	36.8	36.8	37.9	35.8	42.3	30.2	35.2	35.2	35.9	33.4	39.8	29.2	33.4	33.4	33.6	33.5	37.1	28.1
1080	75	34.2	28.8	38.6	22.4	43.0	15.6	32.3	27.8	36.4	21.4	40.3	14.5	30.2	26.7	34.0	20.3	37.4	13.4
	80	34.5	33.8	38.6	27.9	43.0	21.2	32.7	32.7	36.4	26.9	40.4	20.1	30.8	30.8	34.0	25.8	37.5	18.9
	85	36.3	36.3	38.6	33.3	43.1	26.7	34.5	34.5	36.4	32.3	40.4	25.6	32.7	32.7	34.1	30.6	37.5	24.5
	90	38.3	38.3	38.9	38.2	43.1	32.2	36.6	36.6	36.8	36.8	40.5	31.1	34.6	34.6	34.7	34.7	37.6	30.0
1200	75	34.9	30.4	39.3	23.4	43.6	15.9	32.9	29.4	37.0	22.3	40.8	14.8	30.7	28.0	34.4	21.2	37.7	13.6
	80	35.4	35.4	39.3	29.4	43.7	22.0	33.6	33.6	37.0	28.4	40.9	20.9	31.6	31.6	34.5	27.3	37.8	19.7
	85	37.5	37.5	39.3	35.4	43.7	28.1	35.7	35.7	37.1	33.7	40.9	27.0	33.7	33.7	34.6	32.2	37.8	25.8
	90	39.7	39.7	39.8	39.8	43.7	34.1	37.8	37.8	37.9	37.9	41.7	33.2	35.7	35.7	35.7	35.7	37.9	31.8
1320	75	35.5	32.0	39.8	24.3	44.1	16.1	33.4	30.5	37.4	23.2	41.2	15.0	31.0	28.7	34.8	22.1	37.9	13.7
	80	36.4	36.4	39.9	30.9	44.1	22.8	34.4	34.4	37.5	29.8	41.3	21.7	32.5	32.5	34.9	28.6	38.0	20.4
	85	38.6	38.6	40.0	36.4	44.2	29.4	36.7	36.7	37.6	35.3	41.3	28.3	34.6	34.6	35.0	34.5	38.1	27.1
	90	40.9	40.9	40.9	40.9	44.2	36.0	38.9	38.9	38.9	38.9	41.4	34.8	36.5	36.5	36.6	36.6	38.2	33.6
1440	75	36.0	33.3	40.3	25.2	44.5	16.4	33.9	31.9	37.8	24.1	41.5	15.2	31.4	30.7	35.1	22.9	38.1	13.9
	80	37.1	37.1	40.4	32.3	44.6	23.6	35.3	35.3	37.9	31.2	41.6	22.4	33.2	33.2	35.2	30.0	38.2	21.1
	85	39.5	39.5	40.5	38.4	44.6	30.8	37.5	37.5	38.0	37.5	41.6	29.6	35.3	35.3	35.4	35.4	38.3	28.3
	90	41.9	41.9	41.9	41.9	44.6	37.8	39.7	39.7	39.8	39.8	41.7	36.6	37.2	37.2	37.3	37.3	38.4	34.9
		Ambient Temperature																	
		115						120						125					
Air	Ent	Entering Wet Bulb																	
Flow	DB	61		67		73		61		67		73		61		67		73	
cfm	(°F)	MBh	SHC	MBh	SHC	MBh	SHC	MBh	SHC	MBh	SHC	MBh	SHC	MBh	SHC	MBh	SHC	MBh	SHC
960	75	27.3	23.9	30.9	18.2	33.8	11.9	26.2	23.2	29.5	17.6	32.0	11.2	25.0	22.6	28.0	17.0	30.3	10.6
	80	27.7	27.7	30.9	23.1	33.8	16.9	26.8	26.8	29.5	22.6	32.0	16.2	25.8	25.8	28.1	21.9	30.3	15.6
	85	29.6	29.6	30.9	27.9	33.9	21.9	28.6	28.6	29.6	27.2	32.1	21.2	27.4	27.4	28.2	26.3	30.4	20.6
	90	31.4	31.4	31.4	31.4	33.9	26.8	30.2	30.2	30.3	30.3	32.2	26.1	28.9	28.9	29.0	29.0	30.4	25.4
1080	75	27.8	25.3	31.3	19.1	34.0	12.1	26.6	24.2	29.9	18.5	32.3	11.4	25.4	23.9	28.3	17.8	30.5	10.8
	80	28.8	28.8	31.4	24.7	34.1	17.6	27.7	27.7	29.9	24.0	32.4	17.0	26.6	26.6	28.4	23.5	30.6	16.3
	85	30.7	30.7	31.5	29.5	34.1	23.2	29.5	29.5	30.0	27.9	32.5	22.6	28.3	28.3	28.5	28.5	30.6	21.9
	90	32.4	32.4	32.4	32.4	34.2	28.6	31.1	31.1	31.1	31.1	32.5	28.0	29.6	29.6	29.6	29.6	30.7	27.2
1200	75	28.3	25.8	31.7	20.0	34.3	12.3	27.0	25.9	30.2	19.4	32.5	11.6	25.7	25.7	28.6	18.7	31.4	11.2
	80	29.6	29.6	31.7	26.4	34.4	18.4	28.5	28.5	30.2	25.2	32.6	17.7	27.3	27.3	28.6	24.1	30.7	17.0
	85	31.5	31.5	31.9	31.9	34.4	24.5	30.3	30.3	30.4	30.4	32.7	23.8	28.9	28.9	28.9	28.9	30.8	23.2
	90	33.2	33.2	33.2	33.2	34.5	30.5	31.7	31.7	31.7	31.7	32.7	29.4	30.2	30.2	30.2	30.2	30.9	28.4
1320	75	28.6	28.6	32.0	20.9	34.5	12.4	27.4	27.4	30.4	20.2	32.7	11.8	26.1	26.1	28.7	19.5	31.7	11.4
	80	30.3	30.3	32.0	27.4	34.6	19.1	29.1	29.1	30.5	26.3	32.8	18.4	27.8	27.8	28.8	25.1	30.8	17.7
	85	32.2	32.2	32.3	32.3	34.6	25.8	30.9	30.9	30.9	30.9	32.8	25.1	29.3	29.3	29.3	29.3	31.8	24.6
	90	33.8	33.8	33.8	33.8	34.7	31.2	32.2	32.2	32.3	32.3	32.9	30.6	30.6	30.6	30.6	30.6	31.9	30.6
1440	75	29.0	29.0	32.2	21.7	34.7	12.6	27.7	27.7	30.6	21.0	32.8	11.9	26.5	26.5	28.8	20.3	30.8	11.2
	80	30.9	30.9	32.2	28.7	34.7	19.8	29.7	29.7	30.6	27.7	32.9	19.1	28.3	28.3	28.9	26.5	30.9	18.4
	85	32.8	32.8	32.8	32.8	34.8	26.9	31.3	31.3	31.3	31.3	33.0	26.2	29.5	29.5	29.6	29.6	32.1	25.8
	90	34.2	34.2	34.3	34.3	34.9	31.9	32.7	32.7	32.7	32.7	33.0	32.6	31.9	31.9	31.9	31.9	32.3	32.2

Notes:

1. All capacities shown are gross and have not considered indoor fan heat. To obtain **NET** cooling capacity subtract indoor fan heat. For indoor fan heat formula, refer to appropriate airflow table notes.
2. MBh = Total Gross Capacity
3. SHC = Sensible Heat Capacity

Table 4. Gross cooling capacities 4 tons - E/GBC048A3,4,W,K

		Ambient Temperature																	
		85						95						105					
Air	Ent	Entering Wet Bulb																	
Flow	DB	61		67		73		61		67		73		61		67		73	
cfm	(°F)	MBh	SHC	MBh	SHC	MBh	SHC	MBh	SHC	MBh	SHC	MBh	SHC	MBh	SHC	MBh	SHC	MBh	SHC
1280	75	45.9	37.0	51.9	29.3	58.1	20.2	43.6	35.8	49.4	28.2	55.0	19.0	41.0	34.4	46.3	26.7	51.5	18.5
	80	46.1	42.4	51.9	36.0	58.1	27.9	43.8	41.5	49.5	34.8	55.0	26.6	41.3	40.5	46.3	33.4	51.5	25.2
	85	47.7	47.7	52.0	42.5	58.2	34.6	45.7	45.7	49.5	41.3	55.0	33.3	43.7	43.7	46.4	39.9	51.6	31.9
	90	50.5	50.5	52.1	47.9	58.2	41.2	48.6	48.6	49.7	46.2	55.1	40.0	46.2	46.2	46.7	45.9	51.6	38.6
1440	75	47.0	39.3	53.1	30.7	59.3	20.5	44.5	38.0	50.5	29.5	56.0	20.3	41.8	36.6	47.2	28.1	52.3	18.8
	80	47.4	45.8	53.1	38.1	59.3	29.1	45.0	44.7	50.6	36.9	56.0	27.8	42.6	42.6	47.2	35.4	52.3	26.3
	85	49.7	49.7	53.1	45.4	59.3	36.6	47.7	47.7	50.6	44.1	56.0	35.2	45.4	45.4	47.3	42.5	52.3	33.8
	90	52.8	52.8	53.7	50.8	59.4	44.0	50.7	50.7	51.1	50.7	56.1	42.6	47.9	47.9	48.0	48.0	52.4	41.2
1600	75	47.9	41.4	54.3	32.2	60.2	22.0	45.4	40.1	51.1	30.7	56.7	20.6	42.6	38.5	47.9	29.3	52.8	19.1
	80	48.6	48.6	54.4	40.3	60.3	30.2	46.2	46.2	51.1	38.8	56.8	28.9	44.0	44.0	47.9	37.3	52.9	27.3
	85	51.5	51.5	54.4	48.2	60.3	38.4	49.4	49.4	51.2	46.4	56.8	37.1	46.7	46.7	48.0	44.0	52.9	35.6
	90	54.7	54.7	55.0	55.0	60.3	46.6	52.1	52.1	52.1	52.1	56.8	45.1	49.4	49.4	49.5	49.5	53.0	43.5
1760	75	48.8	43.6	55.2	33.5	61.0	22.4	46.1	41.9	51.8	32.0	57.4	20.9	43.2	39.7	48.4	30.5	53.3	19.4
	80	49.8	49.8	55.2	42.2	61.1	31.3	47.6	47.6	51.8	40.8	57.4	29.9	45.2	45.2	48.5	39.2	53.3	28.4
	85	53.1	53.1	55.3	50.0	61.1	40.3	50.8	50.8	52.0	48.1	57.4	38.8	47.9	47.9	48.7	45.4	53.4	37.3
	90	56.1	56.1	56.1	56.1	61.1	49.0	53.6	53.6	53.6	53.6	57.5	47.5	50.7	50.7	50.8	50.8	53.4	45.9
1920	75	49.5	45.0	55.6	34.5	61.7	22.7	46.7	43.1	52.4	33.1	57.9	21.2	43.8	41.0	48.9	31.7	53.6	19.6
	80	51.1	51.1	55.6	44.1	61.7	32.4	48.8	48.8	52.4	42.7	57.9	30.9	46.1	46.1	48.9	41.0	53.7	29.3
	85	54.5	54.5	55.7	52.2	61.7	42.0	51.8	51.8	52.6	50.9	58.0	40.6	49.0	49.0	49.3	49.3	53.7	38.9
	90	57.5	57.5	57.6	57.6	61.7	51.4	54.8	54.8	54.9	54.9	58.0	49.9	51.8	51.8	51.8	51.8	53.8	47.8
		Ambient Temperature																	
		115						120						125					
Air	Ent	Entering Wet Bulb																	
Flow	DB	61		67		73		61		67		73		61		67		73	
cfm	(°F)	MBh	SHC	MBh	SHC	MBh	SHC	MBh	SHC	MBh	SHC	MBh	SHC	MBh	SHC	MBh	SHC	MBh	SHC
1280	75	38.2	33.0	43.1	25.3	47.5	16.9	36.7	32.2	41.3	24.5	45.3	16.1	35.1	31.5	39.4	23.7	42.8	15.1
	80	38.8	38.8	43.1	31.9	47.6	23.7	37.5	37.5	41.4	31.2	45.3	22.8	36.1	36.1	39.5	30.3	42.8	21.9
	85	41.2	41.2	43.2	38.4	47.6	30.4	39.9	39.9	41.4	37.3	45.4	29.5	38.4	38.4	39.6	35.9	42.9	28.6
	90	43.6	43.6	43.7	43.7	47.7	37.0	42.2	42.2	42.2	42.2	45.4	36.1	40.6	40.6	40.6	40.6	43.0	35.2
1440	75	39.0	35.1	43.8	26.6	48.0	17.2	37.4	34.2	41.9	25.8	45.6	16.3	35.8	32.9	39.9	24.9	43.0	15.3
	80	40.2	40.2	43.8	33.9	48.1	24.7	38.8	38.8	42.0	33.2	45.7	23.8	37.3	37.3	40.0	32.3	43.1	22.8
	85	42.7	42.7	43.9	40.0	48.1	32.2	41.2	41.2	42.1	39.9	45.8	31.3	39.6	39.6	40.2	37.4	43.1	30.3
	90	45.1	45.1	45.2	45.2	48.2	39.4	43.5	43.5	43.6	43.6	45.8	38.5	41.7	41.7	41.7	41.7	43.2	37.5
1600	75	39.7	36.3	44.3	27.8	48.4	17.4	38.0	35.3	42.4	27.0	45.8	16.5	36.3	35.1	40.3	26.1	43.2	15.5
	80	41.3	41.3	44.4	35.7	48.4	25.7	39.9	39.9	42.4	34.9	45.9	24.8	38.3	38.3	40.4	34.0	44.9	24.3
	85	43.9	43.9	44.6	42.6	48.5	33.9	42.3	42.3	42.7	42.2	46.0	32.9	40.6	40.6	40.7	40.7	43.3	31.8
	90	46.4	46.4	46.4	46.4	48.6	41.8	44.6	44.6	44.6	44.6	46.1	40.8	42.5	42.5	42.5	42.5	43.4	39.4
1760	75	40.1	38.3	44.8	28.9	48.6	17.6	38.5	37.8	42.8	28.1	46.0	16.7	36.8	36.8	40.6	27.2	43.4	15.8
	80	42.3	42.3	44.8	37.6	48.7	26.6	40.7	40.7	42.8	36.7	46.1	25.7	39.1	39.1	40.7	35.8	43.5	24.8
	85	44.9	44.9	45.2	45.2	48.8	35.6	43.2	43.2	43.3	43.3	46.2	34.6	41.3	41.3	41.4	41.4	43.6	33.5
	90	47.3	47.3	47.4	47.4	48.8	43.6	45.3	45.3	45.4	45.4	46.2	42.4	43.0	43.0	43.0	43.0	43.7	40.8
1920	75	40.6	40.4	45.1	30.1	48.8	17.8	39.0	39.0	43.1	29.2	47.7	17.4	37.3	37.3	40.8	28.3	43.6	16.0
	80	43.1	43.1	45.2	39.3	48.9	27.6	41.5	41.5	43.1	38.4	46.3	26.6	39.7	39.7	40.9	36.9	43.7	25.7
	85	45.8	45.8	45.8	45.8	49.0	37.0	44.0	44.0	44.0	44.0	46.3	35.9	41.9	41.9	41.9	41.9	43.7	34.9
	90	48.1	48.1	48.1	48.1	49.0	45.5	45.8	45.8	45.9	45.9	48.0	44.2	43.5	43.5	43.5	43.5	43.8	43.5

Notes:

1. All capacities shown are gross and have not considered indoor fan heat. To obtain **NET** cooling capacity subtract indoor fan heat. For indoor fan heat formula, refer to appropriate airflow table notes.
2. MBh = Total Gross Capacity
3. SHC = Sensible Heat Capacity



Performance Data

Table 5. Gross cooling capacities 5 tons - E/GBC060A3,4,W,K

		Ambient Temperature																	
		85						95						105					
Air	Ent	Entering Wet Bulb																	
Flow	DB	61		67		73		61		67		73		61		67		73	
cfm	(°F)	MBh	SHC	MBh	SHC	MBh	SHC	MBh	SHC	MBh	SHC	MBh	SHC	MBh	SHC	MBh	SHC	MBh	SHC
1600	75	56.0	45.1	62.6	35.5	69.5	23.9	52.7	43.4	59.0	33.8	65.1	23.4	49.3	41.6	55.0	32.0	60.4	21.5
	80	56.1	51.9	62.6	43.7	69.5	33.5	52.8	50.7	59.0	42.0	65.2	31.7	49.4	48.8	55.0	40.2	60.5	29.8
	85	57.4	57.4	62.5	51.6	69.5	41.8	54.7	54.7	58.9	49.9	65.2	40.0	51.7	51.7	55.0	48.0	60.5	38.1
	90	60.5	60.5	62.6	57.0	69.5	50.0	57.7	57.7	59.0	57.0	65.3	48.2	54.6	54.6	55.1	55.0	60.5	46.1
1800	75	57.3	47.9	63.9	37.2	70.7	25.7	53.8	46.0	60.0	35.4	66.2	23.8	50.2	44.2	55.9	33.5	61.2	21.9
	80	57.4	55.8	63.9	46.2	70.8	34.9	53.9	53.9	60.0	44.4	66.2	33.1	50.5	50.5	55.8	42.4	61.2	31.1
	85	59.7	59.7	63.8	55.0	70.8	44.2	56.6	56.6	60.0	53.1	66.3	42.3	53.4	53.4	55.9	49.8	61.3	40.3
	90	62.8	62.8	63.9	62.7	71.5	53.6	59.8	59.8	60.1	60.1	66.3	51.2	56.4	56.4	56.5	56.5	61.3	49.2
2000	75	58.3	50.5	65.0	38.7	71.8	26.1	54.6	48.6	60.9	36.9	67.0	24.2	50.8	45.6	56.5	35.0	61.7	22.2
	80	58.5	58.5	65.6	49.0	71.8	36.3	55.0	55.0	60.9	46.6	67.0	34.4	51.8	51.8	56.5	44.6	61.8	32.4
	85	61.4	61.4	64.8	57.6	71.8	46.5	58.3	58.3	60.8	54.8	67.1	44.5	54.9	54.9	56.5	53.5	61.9	42.5
	90	64.8	64.8	64.9	64.9	71.8	56.2	61.6	61.6	61.6	61.6	67.1	54.2	58.0	58.0	58.0	58.0	61.9	52.2
2200	75	59.2	52.8	65.8	40.3	72.6	26.5	55.3	49.5	61.6	38.4	67.6	24.6	51.3	48.2	57.0	36.4	62.1	22.5
	80	59.7	59.7	65.7	50.8	72.7	37.6	56.4	56.4	61.5	48.9	67.7	35.7	53.0	53.0	57.0	46.8	62.2	33.6
	85	63.0	63.0	65.7	60.5	72.7	48.7	59.7	59.7	61.5	58.4	67.7	46.7	56.1	56.1	57.0	56.2	62.3	44.2
	90	66.5	66.5	66.6	66.6	72.6	59.2	63.1	63.1	63.2	63.2	67.7	57.2	59.2	59.2	59.3	59.3	62.4	54.5
2400	75	59.9	54.2	66.5	41.7	73.3	26.9	55.8	52.4	62.2	39.8	68.1	24.9	51.6	50.2	57.4	37.7	62.5	22.8
	80	60.7	60.7	66.4	53.1	73.3	38.9	57.5	57.5	62.1	51.1	68.2	36.9	53.9	53.9	57.4	49.0	62.6	34.8
	85	64.4	64.4	66.2	63.2	73.4	50.4	61.0	61.0	61.9	61.1	68.3	48.3	57.2	57.2	57.3	57.3	62.7	46.1
	90	68.1	68.1	68.1	68.1	73.3	62.2	64.4	64.4	64.5	64.5	68.2	58.9	60.3	60.3	60.3	60.3	62.6	56.8
		Ambient Temperature																	
		115						120						125					
Air	Ent	Entering Wet Bulb																	
Flow	DB	61		67		73		61		67		73		61		67		73	
cfm	(°F)	MBh	SHC	MBh	SHC	MBh	SHC	MBh	SHC	MBh	SHC	MBh	SHC	MBh	SHC	MBh	SHC	MBh	SHC
1600	75	45.5	39.7	50.6	30.0	55.0	19.4	43.5	38.7	48.2	29.0	52.3	18.4	41.3	37.1	45.5	27.8	49.2	17.2
	80	45.8	45.8	50.6	38.2	55.1	27.8	44.0	44.0	48.2	36.9	52.4	26.7	42.2	42.2	45.5	35.7	49.3	25.6
	85	48.5	48.5	50.7	45.4	55.2	36.0	46.6	46.6	48.2	43.6	52.3	34.9	44.5	44.5	45.6	43.2	49.4	33.7
	90	51.1	51.1	51.1	51.1	55.2	44.0	49.0	49.0	49.1	49.1	52.4	42.9	46.7	46.7	46.8	46.8	49.5	41.7
1800	75	46.2	41.6	51.2	31.5	55.6	19.7	44.0	40.4	48.6	30.4	52.7	18.7	41.7	39.4	45.9	29.2	49.5	17.5
	80	47.1	47.1	51.2	40.3	55.7	29.0	45.3	45.3	48.7	39.1	52.8	27.9	43.2	43.2	45.9	37.9	50.6	27.0
	85	49.9	49.9	51.3	48.5	55.7	38.1	47.9	47.9	48.7	47.2	52.9	36.9	45.6	45.6	45.9	45.9	49.8	35.6
	90	52.6	52.6	52.6	52.6	55.8	47.0	50.3	50.3	50.3	50.3	52.9	45.9	47.8	47.8	47.8	47.8	50.6	44.3
2000	75	46.6	43.9	51.7	32.9	56.1	20.0	44.4	42.7	49.0	31.7	53.0	18.9	42.0	41.4	46.1	30.5	49.7	17.7
	80	48.3	48.3	51.7	42.5	56.1	30.2	46.3	46.3	49.0	41.3	53.1	29.1	44.1	44.1	46.2	40.1	51.0	28.3
	85	51.1	51.1	51.7	51.2	56.1	39.9	48.9	48.9	49.0	49.0	53.2	38.7	46.4	46.4	46.4	46.4	50.0	37.5
	90	53.7	53.7	53.7	53.7	56.2	49.2	51.3	51.3	51.3	51.3	53.3	47.3	48.7	48.7	48.8	48.8	51.0	47.0
2200	75	47.0	45.9	52.0	34.1	56.4	20.3	44.7	44.7	49.2	33.0	54.0	19.4	42.2	42.2	46.2	31.3	51.5	18.4
	80	49.2	49.2	52.0	44.6	56.5	31.4	47.1	47.1	49.3	43.0	53.3	30.3	44.7	44.7	46.3	41.2	50.0	29.0
	85	52.0	52.0	52.1	52.1	56.5	41.9	49.7	49.7	49.7	49.7	53.4	40.7	47.0	47.0	47.1	47.1	50.1	39.4
	90	54.6	54.6	54.7	54.7	56.4	51.8	52.2	52.2	52.2	52.2	53.4	50.5	50.1	50.1	50.2	50.2	51.4	49.6
2400	75	47.2	47.2	52.2	35.5	56.6	20.5	44.9	44.9	49.4	33.7	54.4	19.7	42.7	42.7	46.3	32.4	49.9	18.1
	80	50.0	50.0	52.3	45.6	56.7	32.5	47.7	47.7	49.5	43.6	53.5	31.1	45.2	45.2	46.3	43.3	50.1	29.6
	85	52.8	52.8	52.8	52.8	56.8	43.8	50.3	50.3	50.3	50.3	53.6	42.5	47.7	47.7	47.7	47.7	51.7	41.7
	90	55.4	55.4	55.4	55.4	56.7	54.2	52.8	52.8	52.9	52.9	54.1	53.1	51.1	51.1	51.2	51.2	51.7	51.7

- Notes:**
1. All capacities shown are gross and have not considered indoor fan heat. To obtain **NET** cooling capacity subtract indoor fan heat. For indoor fan heat formula, refer to appropriate airflow table notes.
 2. MBh = Total Gross Capacity
 3. SHC = Sensible Heat Capacity

Table 6. Belt drive evaporator fan performance - 3 tons cooling only units - EBC036A3, 4, W, K - downflow airflow

External Static Pressure (Inches of Water)																					
		0.10		0.20		0.30		0.40		0.50		0.60		0.70		0.80		0.90		1.00	
cfm	rpm	bhp	rpm	bhp	rpm	bhp	rpm	bhp	rpm	bhp	rpm	bhp	rpm	bhp	rpm	bhp	rpm	bhp	rpm	bhp	
1-hp standard motor and pulley																					
960	---	---	---	---	587	0.17	645	0.21	698	0.25	747	0.30	792	0.34	835	0.38	875	0.43	913	0.48	
1080	---	---	---	---	612	0.21	669	0.25	720	0.30	768	0.34	813	0.39	855	0.44	895	0.49	933	0.54	
1200	---	---	---	---	639	0.25	693	0.30	743	0.34	790	0.39	834	0.45	876	0.50	915	0.55	953	0.60	
1320	---	---	608	0.25	666	0.30	719	0.35	768	0.40	813	0.45	857	0.51	898	0.56	937	0.62	974	0.68	
1440	581	0.24	642	0.30	697	0.35	748	0.41	795	0.46	840	0.52	882	0.58	922	0.64	960	0.70	997	0.76	
2-hp oversized motor and pulley																					

Continued

External Static Pressure (Inches of Water)											
		1.10		1.20		1.30		1.40		1.50	
cfm	rpm	bhp	rpm	bhp	rpm	bhp	rpm	bhp	rpm	bhp	
2-hp oversized motor and pulley											
960	950	0.53	984	0.58	1018	0.63	1050	0.68	1081	0.73	
1080	969	0.59	1004	0.64	1038	0.70	1070	0.75	1101	0.81	
1200	989	0.66	1024	0.72	1057	0.77	1089	0.83	1121	0.89	
1320	1010	0.74	1044	0.80	1077	0.86	1109	0.92	1140	0.98	
1440	1032	0.82	1066	0.89	1099	0.95	1131	1.02	1162	1.08	

Notes:

1. For Standard Evaporator Fan Speed (rpm), reference [Table 24, p. 39](#).
2. For Oversized Evaporator Fan Speed (rpm), reference [Table 25, p. 39](#).
3. 1-hp fan motor heat (MBh) = 2.8328 x Fan bhp. + 0.4714, 2-hp fan motor heat (MBh) = 2.7146 x Fan bhp. + 0.816.
4. Data includes pressure drop due to standard filters and wet coils. No accessories or options are included in pressure drop data.
5. Factory supplied motors, in commercial equipment, are definite purpose motors, specifically designed and tested to operate reliably and continuously at all cataloged conditions. Using the full horsepower range of our fan motors as shown in our tabular data will not result in nuisance tripping or premature motor failure. Our product's warranty will not be affected.



Performance Data

Table 7. Belt drive evaporator fan performance - 3 tons cooling only units - EBC036A3, 4, W, K - horizontal airflow

External Static Pressure (Inches of Water)																					
		0.10		0.20		0.30		0.40		0.50		0.60		0.70		0.80		0.90		1.00	
cfm	rpm	bhp	rpm	bhp	rpm	bhp	rpm	bhp	rpm	bhp	rpm	bhp	rpm	bhp	rpm	bhp	rpm	bhp	rpm	bhp	
1-hp standard motor and pulley																					
960	---	---	---	---	596	0.18	653	0.22	706	0.26	754	0.30	799	0.35	841	0.39	881	0.44	919	0.49	
1080	---	---	---	---	623	0.21	678	0.26	729	0.30	776	0.35	821	0.40	862	0.45	902	0.50	940	0.55	
1200	---	---	591	0.21	650	0.26	703	0.31	753	0.35	799	0.40	843	0.46	884	0.51	923	0.56	961	0.62	
1320	---	---	622	0.26	678	0.31	730	0.36	778	0.41	824	0.47	866	0.52	907	0.58	945	0.63	982	0.69	
1440	599	0.26	659	0.31	712	0.37	762	0.42	809	0.48	852	0.54	894	0.60	934	0.66	971	0.72	1008	0.78	
																		2-hp oversized motor and pulley			

Continued

External Static Pressure (Inches of Water)											
		1.10		1.20		1.30		1.40		1.50	
cfm	rpm	bhp	rpm	bhp	rpm	bhp	rpm	bhp	rpm	bhp	
2-hp oversized motor and pulley											
960	955	0.53	989	0.58	1023	0.64	1055	0.69	1086	0.74	
1080	976	0.60	1010	0.65	1043	0.71	1076	0.76	1107	0.82	
1200	996	0.67	1031	0.73	1064	0.79	1096	0.84	1127	0.90	
1320	1018	0.75	1052	0.81	1085	0.87	1116	0.93	1147	1.00	
1440	1042	0.84	1076	0.91	1109	0.97	1140	1.04	1171	1.10	

Notes:

1. For Standard Evaporator Fan Speed (rpm), reference [Table 24, p. 39](#).
2. For Oversized Evaporator Fan Speed (rpm), reference [Table 25, p. 39](#).
3. 1-hp fan motor heat (MBh) = 2.8328 x Fan bhp. + 0.4714, 2-hp fan motor heat (MBh) = 2.7146 x Fan bhp. + 0.816.
4. Data includes pressure drop due to standard filters and wet coils. No accessories or options are included in pressure drop data.
5. Factory supplied motors, in commercial equipment, are definite purpose motors, specifically designed and tested to operate reliably and continuously at all cataloged conditions. Using the full horsepower range of our fan motors as shown in our tabular data will not result in nuisance tripping or premature motor failure. Our product's warranty will not be affected.

Table 8. Belt drive evaporator fan performance - 3 tons with medium gas heat - GBC036A3, 4, W, K*M - downflow airflow

External Static Pressure (Inches of Water)																					
		0.10		0.20		0.30		0.40		0.50		0.60		0.70		0.80		0.90		1.00	
cfm	rpm	bhp	rpm	bhp	rpm	bhp	rpm	bhp	rpm	bhp	rpm	bhp	rpm	bhp	rpm	bhp	rpm	bhp	rpm	bhp	
1-hp standard motor and pulley																					
960	---	---	---	---	607	0.18	663	0.22	714	0.27	762	0.31	806	0.35	848	0.40	887	0.45	925	0.49	
1080	---	---	---	---	636	0.23	690	0.27	740	0.31	787	0.36	831	0.41	872	0.46	911	0.51	948	0.56	
1200	---	---	610	0.23	667	0.27	719	0.32	768	0.37	813	0.42	856	0.47	896	0.52	935	0.58	972	0.63	
1320	584	0.23	644	0.28	699	0.33	749	0.38	796	0.43	840	0.49	882	0.54	922	0.60	960	0.66	996	0.71	
1440	626	0.28	682	0.34	734	0.39	783	0.45	828	0.51	871	0.56	911	0.62	950	0.68	987	0.75	1023	0.81	
2-hp oversized motor and pulley																					

Continued

External Static Pressure (Inches of Water)											
		1.10		1.20		1.30		1.40		1.50	
cfm	rpm	bhp	rpm	bhp	rpm	bhp	rpm	bhp	rpm	bhp	
2-hp oversized motor and pulley											
960	961	0.54	995	0.59	1028	0.64	1060	0.70	1091	0.75	
1080	984	0.61	1018	0.67	1051	0.72	1083	0.78	1114	0.83	
1200	1007	0.69	1041	0.75	1074	0.80	1105	0.86	1136	0.92	
1320	1031	0.77	1065	0.83	1097	0.89	1128	0.96	1159	1.02	
1440	1057	0.87	1090	0.93	1122	1.00	1153	1.06	1184	1.13	

Notes:

1. For Standard Evaporator Fan Speed (rpm), reference [Table 24, p. 39](#).
2. For Oversized Evaporator Fan Speed (rpm), reference [Table 25, p. 39](#).
3. 1-hp fan motor heat (MBh) = 2.8328 x Fan bhp. + 0.4714, 2-hp fan motor heat (MBh) = 2.7146 x Fan bhp. + 0.816.
4. Data includes pressure drop due to standard filters and wet coils. No accessories or options are included in pressure drop data.
5. Factory supplied motors, in commercial equipment, are definite purpose motors, specifically designed and tested to operate reliably and continuously at all cataloged conditions. Using the full horsepower range of our fan motors as shown in our tabular data will not result in nuisance tripping or premature motor failure. Our product's warranty will not be affected.



Performance Data

Table 9. Belt drive evaporator fan performance - 3 tons with low gas heat - GBC036A3, 4, W, K*L - downflow airflow

External Static Pressure (Inches of Water)																					
		0.10		0.20		0.30		0.40		0.50		0.60		0.70		0.80		0.90		1.00	
cfm	rpm	bhp	rpm	bhp	rpm	bhp	rpm	bhp	rpm	bhp	rpm	bhp	rpm	bhp	rpm	bhp	rpm	bhp	rpm	bhp	
1-hp standard motor and pulley																					
960	---	---	---	---	605	0.18	661	0.22	713	0.27	760	0.31	805	0.35	847	0.40	886	0.44	924	0.49	
1080	---	---	---	---	634	0.22	689	0.27	739	0.31	785	0.36	829	0.41	870	0.46	910	0.51	947	0.56	
1200	---	---	607	0.22	664	0.27	717	0.32	765	0.37	811	0.42	854	0.47	894	0.52	933	0.58	970	0.63	
1320	581	0.22	641	0.27	696	0.32	747	0.38	794	0.43	838	0.48	880	0.54	920	0.60	958	0.65	994	0.71	
1440	622	0.28	679	0.33	731	0.39	780	0.45	825	0.50	868	0.56	909	0.62	948	0.68	985	0.74	1021	0.80	
2-hp oversized motor and pulley																					

Continued

External Static Pressure (Inches of Water)											
		1.10		1.20		1.30		1.40		1.50	
cfm	rpm	bhp	rpm	bhp	rpm	bhp	rpm	bhp	rpm	bhp	
2-hp oversized motor and pulley											
960	960	0.54	994	0.59	1027	0.64	1059	0.69	1090	0.75	
1080	983	0.61	1017	0.66	1050	0.72	1082	0.77	1113	0.83	
1200	1005	0.69	1040	0.74	1072	0.80	1104	0.86	1135	0.92	
1320	1029	0.77	1063	0.83	1095	0.89	1127	0.95	1157	1.02	
1440	1055	0.87	1088	0.93	1120	0.99	1152	1.06	1182	1.13	

Notes:

1. For Standard Evaporator Fan Speed (rpm), reference [Table 24, p. 39](#).
2. For Oversized Evaporator Fan Speed (rpm), reference [Table 25, p. 39](#).
3. 1-hp fan motor heat (MBh) = 2.8328 x Fan bhp. + 0.4714, 2-hp fan motor heat (MBh) = 2.7146 x Fan bhp. + 0.816.
4. Data includes pressure drop due to standard filters and wet coils. No accessories or options are included in pressure drop data.
5. Factory supplied motors, in commercial equipment, are definite purpose motors, specifically designed and tested to operate reliably and continuously at all cataloged conditions. Using the full horsepower range of our fan motors as shown in our tabular data will not result in nuisance tripping or premature motor failure. Our product's warranty will not be affected.

Table 10. Belt drive evaporator fan performance - 3 tons with medium gas heat - GBC036A3, 4, W, K*M - horizontal airflow

External Static Pressure (Inches of Water)																					
		0.10		0.20		0.30		0.40		0.50		0.60		0.70		0.80		0.90		1.00	
cfm	rpm	bhp	rpm	bhp	rpm	bhp	rpm	bhp	rpm	bhp	rpm	bhp	rpm	bhp	rpm	bhp	rpm	bhp	rpm	bhp	
1-hp standard motor and pulley																					
960	---	---	---	---	621	0.19	676	0.23	726	0.28	773	0.32	816	0.36	858	0.41	897	0.46	934	0.51	
1080	---	---	594	0.19	652	0.24	705	0.28	754	0.33	800	0.37	843	0.42	883	0.47	922	0.52	959	0.57	
1200	---	---	630	0.24	685	0.29	736	0.34	783	0.39	828	0.44	870	0.49	910	0.54	948	0.60	984	0.65	
1320	609	0.25	667	0.30	720	0.35	768	0.40	814	0.45	857	0.51	898	0.56	937	0.62	975	0.68	1010	0.74	
1440	655	0.31	709	0.37	759	0.42	806	0.48	850	0.54	892	0.59	931	0.65	969	0.71	1006	0.78	1040	0.84	
2-hp oversized motor and pulley																					

Continued

External Static Pressure (Inches of Water)											
		1.10		1.20		1.30		1.40		1.50	
cfm	rpm	bhp	rpm	bhp	rpm	bhp	rpm	bhp	rpm	bhp	
2-hp oversized motor and pulley											
960	969	0.55	1003	0.61	1036	0.66	1068	0.71	1098	0.76	
1080	994	0.63	1028	0.68	1060	0.74	1092	0.79	1122	0.85	
1200	1019	0.71	1052	0.76	1085	0.82	1116	0.88	1146	0.94	
1320	1045	0.80	1078	0.86	1110	0.92	1141	0.98	1171	1.05	
1440	1074	0.90	1107	0.97	1138	1.03	1169	1.10	1199	1.17	

Notes:

1. For Standard Evaporator Fan Speed (rpm), reference [Table 24, p. 39](#).
2. For Oversized Evaporator Fan Speed (rpm), reference [Table 25, p. 39](#).
3. 1-hp fan motor heat (MBh) = 2.8328 x Fan bhp. + 0.4714, 2-hp fan motor heat (MBh) = 2.7146 x Fan bhp. + 0.816.
4. Data includes pressure drop due to standard filters and wet coils. No accessories or options are included in pressure drop data.
5. Factory supplied motors, in commercial equipment, are definite purpose motors, specifically designed and tested to operate reliably and continuously at all cataloged conditions. Using the full horsepower range of our fan motors as shown in our tabular data will not result in nuisance tripping or premature motor failure. Our product's warranty will not be affected.



Performance Data

Table 11. Belt drive evaporator fan performance - 3 tons with low gas heat - GBC036A3, 4, W, K*L - horizontal airflow

External Static Pressure (Inches of Water)																					
		0.10		0.20		0.30		0.40		0.50		0.60		0.70		0.80		0.90		1.00	
cfm	rpm	bhp	rpm	bhp	rpm	bhp	rpm	bhp	rpm	bhp	rpm	bhp	rpm	bhp	rpm	bhp	rpm	bhp	rpm	bhp	
1-hp standard motor and pulley																					
960	---	---	---	---	618	0.19	673	0.23	724	0.27	771	0.32	814	0.36	856	0.41	895	0.45	932	0.50	
1080	---	---	591	0.19	649	0.24	702	0.28	751	0.33	797	0.37	840	0.42	881	0.47	920	0.52	957	0.57	
1200	---	---	626	0.24	681	0.29	733	0.33	780	0.38	825	0.43	867	0.49	907	0.54	945	0.59	981	0.65	
1320	604	0.24	662	0.29	715	0.34	764	0.40	810	0.45	854	0.50	895	0.56	934	0.62	971	0.67	1007	0.73	
1440	649	0.30	704	0.36	754	0.42	801	0.47	845	0.53	887	0.59	927	0.65	965	0.71	1002	0.77	1037	0.83	
2-hp oversized motor and pulley																					

Continued

External Static Pressure (Inches of Water)											
		1.10		1.20		1.30		1.40		1.50	
cfm	rpm	bhp	rpm	bhp	rpm	bhp	rpm	bhp	rpm	bhp	
2-hp oversized motor and pulley											
960	976	0.56	1010	0.61	1042	0.67	1074	0.72	1104	0.77	
1080	1001	0.64	1035	0.69	1067	0.75	1099	0.80	1129	0.86	
1200	1027	0.72	1060	0.78	1093	0.84	1124	0.90	1154	0.96	
1320	1054	0.81	1086	0.87	1118	0.94	1149	1.00	1179	1.06	
1440	1081	0.92	1113	0.98	1144	1.05	1175	1.11	1204	1.18	

Notes:

1. For Standard Evaporator Fan Speed (rpm), reference [Table 24, p. 39](#).
2. For Oversized Evaporator Fan Speed (rpm), reference [Table 25, p. 39](#).
3. 1-hp fan motor heat (MBh) = 2.8328 x Fan bhp. + 0.4714, 2-hp fan motor heat (MBh) = 2.7146 x Fan bhp. + 0.816.
4. Data includes pressure drop due to standard filters and wet coils. No accessories or options are included in pressure drop data.
5. Factory supplied motors, in commercial equipment, are definite purpose motors, specifically designed and tested to operate reliably and continuously at all cataloged conditions. Using the full horsepower range of our fan motors as shown in our tabular data will not result in nuisance tripping or premature motor failure. Our product's warranty will not be affected.

Table 12. Belt drive evaporator fan performance - 4 tons cooling only units - EBC048A3, 4, W, K - downflow airflow

External Static Pressure (Inches of Water)																					
		0.10		0.20		0.30		0.40		0.50		0.60		0.70		0.80		0.90		1.00	
cfm	rpm	bhp	rpm	bhp	rpm	bhp	rpm	bhp	rpm	bhp	rpm	bhp	rpm	bhp	rpm	bhp	rpm	bhp	rpm	bhp	
1-hp standard motor and pulley																					
1280	---	---	---	---	674	0.27	726	0.31	774	0.36	819	0.40	861	0.45	902	0.50	940	0.55	977	0.60	
1440	---	---	662	0.29	715	0.33	765	0.38	811	0.44	854	0.49	895	0.54	935	0.59	972	0.65	1008	0.70	
1600	653	0.31	708	0.36	758	0.42	805	0.47	849	0.53	891	0.58	931	0.64	969	0.70	1005	0.76	1041	0.82	
1760	695	0.38	747	0.44	795	0.49	840	0.55	882	0.61	923	0.68	962	0.74	999	0.80	1034	0.86	1069	0.93	
1920	752	0.49	801	0.55	846	0.62	889	0.69	929	0.75	968	0.82	1005	0.89	1041	0.95	1076	1.02	1109	1.09	
2-hp oversized motor and pulley																					

Continued

External Static Pressure (Inches of Water)											
		1.10		1.20		1.30		1.40		1.50	
cfm	rpm	bhp	rpm	bhp	rpm	bhp	rpm	bhp	rpm	bhp	
2-hp oversize motor and pulley											
1280	1012	0.65	1046	0.71	1078	0.76	1110	0.81	1141	0.87	
1440	1042	0.76	1076	0.82	1108	0.87	1139	0.93	1170	0.99	
1600	1074	0.88	1107	0.94	1139	1.00	1169	1.06	1199	1.13	
1760	1102	0.99	1134	1.05	1165	1.12	1195	1.19	1225	1.25	
1920	1141	1.16	1172	1.23	1202	1.30	1232	1.37	1261	1.44	

Notes:

1. For Standard Evaporator Fan Speed (rpm), reference [Table 24, p. 39](#).
2. For Oversized Evaporator Fan Speed (rpm), reference [Table 25, p. 39](#).
3. 1-hp fan motor heat (MBh) = 2.8328 x Fan bhp. + 0.4714, 2-hp fan motor heat (MBh) = 2.7146 x Fan bhp. + 0.816.
4. Data includes pressure drop due to standard filters and wet coils. No accessories or options are included in pressure drop data.
5. Factory supplied motors, in commercial equipment, are definite purpose motors, specifically designed and tested to operate reliably and continuously at all cataloged conditions. Using the full horsepower range of our fan motors as shown in our tabular data will not result in nuisance tripping or premature motor failure. Our product's warranty will not be affected.



Performance Data

Table 13. Belt drive evaporator fan performance - 4 tons cooling only units - EBC048A3, 4, W, K - horizontal airflow

External Static Pressure (Inches of Water)																					
		0.10		0.20		0.30		0.40		0.50		0.60		0.70		0.80		0.90		1.00	
cfm	rpm	bhp	rpm	bhp	rpm	bhp	rpm	bhp	rpm	bhp	rpm	bhp	rpm	bhp	rpm	bhp	rpm	bhp	rpm	bhp	
1-hp standard motor and pulley																					
1280	---	---	632	0.23	687	0.28	738	0.32	785	0.37	830	0.42	872	0.46	911	0.51	949	0.56	986	0.61	
1440	623	0.25	679	0.30	731	0.35	779	0.40	824	0.45	867	0.50	908	0.56	946	0.61	983	0.66	1019	0.72	
1600	675	0.33	728	0.38	777	0.44	822	0.49	866	0.55	907	0.61	946	0.66	983	0.72	1019	0.78	1054	0.84	
1760	718	0.40	768	0.46	815	0.52	859	0.58	900	0.64	940	0.70	978	0.76	1014	0.82	1050	0.89	1084	0.95	
1920	781	0.53	828	0.59	871	0.66	913	0.72	952	0.79	990	0.86	1027	0.93	1062	0.99	1095	1.06	1128	1.13	
2-hp oversized motor and pulley																					

Continued

External Static Pressure (Inches of Water)											
		1.10		1.20		1.30		1.40		1.50	
cfm	rpm	bhp	rpm	bhp	rpm	bhp	rpm	bhp	rpm	bhp	
2-hp oversized motor and pulley											
1280	1021	0.67	1054	0.72	1087	0.77	1118	0.83	1148	0.88	
1440	1053	0.78	1086	0.83	1118	0.89	1149	0.95	1179	1.01	
1600	1087	0.90	1120	0.96	1151	1.03	1182	1.09	1211	1.15	
1760	1116	1.02	1148	1.08	1179	1.15	1209	1.21	1238	1.28	
1920	1160	1.20	1191	1.27	1221	1.34	1250	1.42	1279	1.49	

Notes:

1. For Standard Evaporator Fan Speed (rpm), reference [Table 24, p. 39](#).
2. For Oversized Evaporator Fan Speed (rpm), reference [Table 25, p. 39](#).
3. 1-hp fan motor heat (MBh) = 2.8328 x Fan bhp. + 0.4714, 2-hp fan motor heat (MBh) = 2.7146 x Fan bhp. + 0.816.
4. Data includes pressure drop due to standard filters and wet coils. No accessories or options are included in pressure drop data.
5. Factory supplied motors, in commercial equipment, are definite purpose motors, specifically designed and tested to operate reliably and continuously at all cataloged conditions. Using the full horsepower range of our fan motors as shown in our tabular data will not result in nuisance tripping or premature motor failure. Our product's warranty will not be affected.

Table 14. Belt drive evaporator fan performance - 4 tons with medium gas heat - GBC048A3, 4, W, K*M - downflow airflow

External Static Pressure (Inches of Water)																					
		0.10		0.20		0.30		0.40		0.50		0.60		0.70		0.80		0.90		1.00	
cfm	rpm	bhp	rpm	bhp	rpm	bhp	rpm	bhp	rpm	bhp	rpm	bhp	rpm	bhp	rpm	bhp	rpm	bhp	rpm	bhp	
1-hp standard motor and pulley																					
1280	---	---	627	0.23	683	0.27	734	0.32	781	0.36	826	0.41	868	0.46	908	0.51	946	0.56	983	0.61	
1440	---	---	674	0.30	726	0.34	774	0.40	820	0.45	863	0.50	904	0.55	942	0.60	980	0.66	1015	0.71	
1600	667	0.32	721	0.38	770	0.43	816	0.49	860	0.54	901	0.60	941	0.66	978	0.71	1015	0.77	1049	0.83	
1760	709	0.39	760	0.45	807	0.51	852	0.57	894	0.63	934	0.69	972	0.75	1009	0.81	1044	0.88	1078	0.94	
1920	771	0.51	818	0.58	862	0.64	904	0.71	944	0.78	982	0.84	1019	0.91	1054	0.98	1088	1.05	1121	1.12	
2-hp oversized motor and pulley																					

Continued

External Static Pressure (Inches of Water)											
		1.10		1.20		1.30		1.40		1.50	
cfm	rpm	bhp	rpm	bhp	rpm	bhp	rpm	bhp	rpm	bhp	
2-hp oversized motor and pulley											
1280	1018	0.66	1051	0.71	1084	0.77	1115	0.82	1146	0.88	
1440	1050	0.77	1083	0.83	1115	0.89	1146	0.94	1176	1.00	
1600	1083	0.89	1116	0.95	1147	1.02	1178	1.08	1207	1.14	
1760	1111	1.00	1143	1.07	1174	1.14	1204	1.20	1233	1.27	
1920	1153	1.19	1184	1.26	1214	1.33	1244	1.40	1272	1.47	

Notes:

1. For Standard Evaporator Fan Speed (rpm), reference [Table 24, p. 39](#).
2. For Oversized Evaporator Fan Speed (rpm), reference [Table 25, p. 39](#).
3. 1-hp fan motor heat (MBh) = 2.8328 x Fan bhp. + 0.4714, 2-hp fan motor heat (MBh) = 2.7146 x Fan bhp. + 0.816.
4. Data includes pressure drop due to standard filters and wet coils. No accessories or options are included in pressure drop data.
5. Factory supplied motors, in commercial equipment, are definite purpose motors, specifically designed and tested to operate reliably and continuously at all cataloged conditions. Using the full horsepower range of our fan motors as shown in our tabular data will not result in nuisance tripping or premature motor failure. Our product's warranty will not be affected.



Performance Data

Table 15. Belt drive evaporator fan performance - 4 tons with low gas heat - GBC048A3, 4, W, K*L - downflow airflow

External Static Pressure (Inches of Water)																					
		0.10		0.20		0.30		0.40		0.50		0.60		0.70		0.80		0.90		1.00	
cfm	rpm	bhp	rpm	bhp	rpm	bhp	rpm	bhp	rpm	bhp	rpm	bhp	rpm	bhp	rpm	bhp	rpm	bhp	rpm	bhp	
1-hp standard motor and pulley																					
1280	---	---	624	0.23	680	0.27	731	0.32	779	0.36	824	0.41	866	0.46	906	0.51	944	0.56	981	0.61	
1440	---	---	670	0.29	723	0.34	771	0.39	817	0.44	860	0.49	901	0.55	940	0.60	977	0.66	1013	0.71	
1600	663	0.32	717	0.37	767	0.43	813	0.48	857	0.54	898	0.59	938	0.65	976	0.71	1012	0.77	1047	0.83	
1760	705	0.39	756	0.45	803	0.50	848	0.56	890	0.62	930	0.68	968	0.75	1005	0.81	1041	0.87	1075	0.93	
1920	765	0.51	813	0.57	857	0.64	899	0.70	939	0.77	978	0.84	1015	0.90	1050	0.97	1084	1.04	1117	1.11	
2-hp oversize motor and pulley																					

Continued

External Static Pressure (Inches of Water)											
		1.10		1.20		1.30		1.40		1.50	
cfm	rpm	bhp	rpm	bhp	rpm	bhp	rpm	bhp	rpm	bhp	
2-hp oversize motor and pulley											
1280	1016	0.66	1050	0.71	1082	0.77	1114	0.82	1144	0.88	
1440	1048	0.77	1081	0.82	1113	0.88	1144	0.94	1174	1.00	
1600	1081	0.89	1113	0.95	1145	1.01	1175	1.08	1205	1.14	
1760	1108	1.00	1140	1.06	1171	1.13	1201	1.20	1231	1.26	
1920	1149	1.18	1181	1.25	1211	1.32	1240	1.39	1269	1.46	

Notes:

1. For Standard Evaporator Fan Speed (rpm), reference [Table 24, p. 39](#).
2. For Oversized Evaporator Fan Speed (rpm), reference [Table 25, p. 39](#).
3. 1-hp fan motor heat (MBh) = 2.8328 x Fan bhp. + 0.4714, 2-hp fan motor heat (MBh) = 2.7146 x Fan bhp. + 0.816.
4. Data includes pressure drop due to standard filters and wet coils. No accessories or options are included in pressure drop data.
5. Factory supplied motors, in commercial equipment, are definite purpose motors, specifically designed and tested to operate reliably and continuously at all cataloged conditions. Using the full horsepower range of our fan motors as shown in our tabular data will not result in nuisance tripping or premature motor failure. Our product's warranty will not be affected.

Table 16. Belt drive evaporator fan performance - 4 tons with medium gas heat - GBC048A3, 4, W, K*M - horizontal airflow

External Static Pressure (Inches of Water)																					
		0.10		0.20		0.30		0.40		0.50		0.60		0.70		0.80		0.90		1.00	
cfm	rpm	bhp	rpm	bhp	rpm	bhp	rpm	bhp	rpm	bhp	rpm	bhp	rpm	bhp	rpm	bhp	rpm	bhp	rpm	bhp	
1-hp standard motor and pulley																					
1280	---	---	654	0.25	707	0.29	756	0.34	802	0.39	846	0.43	887	0.48	926	0.53	963	0.58	999	0.63	
1440	650	0.27	704	0.32	754	0.37	801	0.42	845	0.48	887	0.53	926	0.58	964	0.64	1001	0.69	1036	0.75	
1600	707	0.36	757	0.41	804	0.47	848	0.53	890	0.58	930	0.64	968	0.70	1005	0.76	1040	0.82	1074	0.88	
1760	753	0.44	801	0.50	845	0.56	888	0.62	928	0.68	966	0.74	1003	0.80	1039	0.87	1073	0.93	1106	1.00	
1920	821	0.58	865	0.65	907	0.71	947	0.78	985	0.85	1021	0.92	1057	0.98	1091	1.05	1124	1.12	1155	1.19	
2-hp oversized motor and pulley																					

Continued

External Static Pressure (Inches of Water)											
		1.10		1.20		1.30		1.40		1.50	
cfm	rpm	bhp	rpm	bhp	rpm	bhp	rpm	bhp	rpm	bhp	
2-hp oversized motor and pulley											
1280	1033	0.69	1067	0.74	1099	0.79	1130	0.85	1160	0.90	
1440	1069	0.80	1102	0.86	1133	0.92	1164	0.98	1193	1.04	
1600	1107	0.94	1139	1.00	1169	1.06	1199	1.13	1228	1.19	
1760	1138	1.06	1170	1.13	1200	1.19	1229	1.26	1258	1.33	
1920	1186	1.26	1217	1.33	1246	1.40	1275	1.48	1302	1.55	

Notes:

1. For Standard Evaporator Fan Speed (rpm), reference [Table 24, p. 39](#).
2. For Oversized Evaporator Fan Speed (rpm), reference [Table 25, p. 39](#).
3. 1-hp fan motor heat (MBh) = 2.8328 x Fan bhp. + 0.4714, 2-hp fan motor heat (MBh) = 2.7146 x Fan bhp. + 0.816.
4. Data includes pressure drop due to standard filters and wet coils. No accessories or options are included in pressure drop data.
5. Factory supplied motors, in commercial equipment, are definite purpose motors, specifically designed and tested to operate reliably and continuously at all cataloged conditions. Using the full horsepower range of our fan motors as shown in our tabular data will not result in nuisance tripping or premature motor failure. Our product's warranty will not be affected.



Performance Data

Table 17. Belt drive evaporator fan performance - 4 tons with low gas heat - GBC048A3, 4, W, K*L - horizontal airflow

External Static Pressure (Inches of Water)																					
		0.10		0.20		0.30		0.40		0.50		0.60		0.70		0.80		0.90		1.00	
cfm	rpm	bhp	rpm	bhp	rpm	bhp	rpm	bhp	rpm	bhp	rpm	bhp	rpm	bhp	rpm	bhp	rpm	bhp	rpm	bhp	
1-hp standard motor and pulley																					
1280	---	---	649	0.25	703	0.29	752	0.34	799	0.38	842	0.43	884	0.48	923	0.53	960	0.58	996	0.63	
1440	644	0.27	699	0.32	749	0.37	796	0.42	841	0.47	883	0.52	922	0.58	960	0.63	997	0.69	1032	0.74	
1600	700	0.35	751	0.41	798	0.46	843	0.52	885	0.58	925	0.63	963	0.69	1000	0.75	1036	0.81	1070	0.87	
1760	745	0.43	794	0.49	839	0.55	881	0.61	922	0.67	961	0.73	998	0.80	1034	0.86	1068	0.92	1101	0.99	
1920	813	0.57	857	0.64	899	0.70	940	0.77	978	0.84	1015	0.90	1050	0.97	1084	1.04	1117	1.11	1150	1.18	
2-hp oversized motor and pulley																					

Continued

External Static Pressure (Inches of Water)											
		1.10		1.20		1.30		1.40		1.50	
cfm	rpm	bhp	rpm	bhp	rpm	bhp	rpm	bhp	rpm	bhp	
2-hp oversized motor and pulley											
1280	1031	0.68	1064	0.74	1096	0.79	1127	0.84	1157	0.90	
1440	1066	0.80	1098	0.86	1130	0.91	1161	0.97	1190	1.03	
1600	1103	0.93	1134	0.99	1165	1.05	1196	1.12	1225	1.18	
1760	1134	1.05	1165	1.12	1195	1.18	1225	1.25	1254	1.32	
1920	1181	1.25	1211	1.32	1240	1.39	1269	1.46	1297	1.54	

Notes:

1. For Standard Evaporator Fan Speed (rpm), reference [Table 24, p. 39](#).
2. For Oversized Evaporator Fan Speed (rpm), reference [Table 25, p. 39](#).
3. 1-hp fan motor heat (MBh) = 2.8328 x Fan bhp. + 0.4714, 2-hp fan motor heat (MBh) = 2.7146 x Fan bhp. + 0.816.
4. Data includes pressure drop due to standard filters and wet coils. No accessories or options are included in pressure drop data.
5. Factory supplied motors, in commercial equipment, are definite purpose motors, specifically designed and tested to operate reliably and continuously at all cataloged conditions. Using the full horsepower range of our fan motors as shown in our tabular data will not result in nuisance tripping or premature motor failure. Our product's warranty will not be affected.

Table 18. Belt drive evaporator fan performance - 5 tons cooling only units - EBC060A3, 4, W, K - downflow airflow

External Static Pressure (Inches of Water)																					
		0.10		0.20		0.30		0.40		0.50		0.60		0.70		0.80		0.90		1.00	
cfm	rpm	bhp	rpm	bhp	rpm	bhp	rpm	bhp	rpm	bhp	rpm	bhp	rpm	bhp	rpm	bhp	rpm	bhp	rpm	bhp	
1-hp standard motor and pulley																					
1600	---	---	712	0.37	762	0.42	808	0.48	852	0.53	894	0.59	933	0.64	971	0.70	1007	0.76	1042	0.82	
1800	722	0.42	772	0.48	818	0.54	862	0.61	904	0.67	943	0.73	981	0.79	1017	0.86	1052	0.92	1086	0.99	
2000	787	0.56	833	0.62	876	0.69	918	0.76	957	0.83	995	0.90	1031	0.97	1066	1.04	1099	1.11	1132	1.18	
2200	852	0.72	895	0.79	935	0.87	974	0.94	1012	1.02	1048	1.09	1082	1.17	1116	1.25	1148	1.32	1180	1.40	
2400	917	0.91	957	0.99	995	1.07	1032	1.15	1068	1.23	1102	1.32	1135	1.40	1167	1.48	1198	1.57	1229	1.65	
2-hp oversized motor and pulley																					

Continued

External Static Pressure (Inches of Water)											
		1.10		1.20		1.30		1.40		1.50	
cfm	rpm	bhp	rpm	bhp	rpm	bhp	rpm	bhp	rpm	bhp	
1-hp standard motor and pulley				2-hp oversized motor and pulley							
1600	1076	0.88	1109	0.94	1140	1.00	1171	1.07	1201	1.13	
1800	1119	1.05	1150	1.12	1181	1.19	1211	1.26	1240	1.32	
2000	1164	1.25	1194	1.32	1224	1.40	1254	1.47	1282	1.55	
2200	1210	1.48	1240	1.56	1269	1.64	1297	1.72	1325	1.80	
2400	1258	1.73	1287	1.82	1315	1.90	1343	1.99	1370	2.08	

Notes:

1. For Standard Evaporator Fan Speed (rpm), reference [Table 24, p. 39](#).
2. For Oversized Evaporator Fan Speed (rpm), reference [Table 25, p. 39](#).
3. 1-hp fan motor heat (MBh) = 2.8328 x Fan bhp. + 0.4714, 2-hp fan motor heat (MBh) = 2.7146 x Fan bhp. + 0.816.
4. Data includes pressure drop due to standard filters and wet coils. No accessories or options are included in pressure drop data.
5. Factory supplied motors, in commercial equipment, are definite purpose motors, specifically designed and tested to operate reliably and continuously at all cataloged conditions. Using the full horsepower range of our fan motors as shown in our tabular data will not result in nuisance tripping or premature motor failure. Our product's warranty will not be affected.



Performance Data

Table 19. Belt drive evaporator fan performance - 5 tons cooling only units - EBC060A3, 4, W, K - horizontal airflow

External Static Pressure (Inches of Water)																					
		0.10		0.20		0.30		0.40		0.50		0.60		0.70		0.80		0.90		1.00	
cfm	rpm	bhp	rpm	bhp	rpm	bhp	rpm	bhp	rpm	bhp	rpm	bhp	rpm	bhp	rpm	bhp	rpm	bhp	rpm	bhp	
1-hp standard motor and pulley																					
1600	---	---	726	0.38	775	0.44	821	0.49	864	0.55	905	0.60	944	0.66	981	0.72	1017	0.78	1052	0.84	
1800	739	0.44	788	0.50	833	0.56	876	0.63	917	0.69	956	0.75	993	0.81	1029	0.88	1064	0.94	1097	1.01	
2000	806	0.59	851	0.65	894	0.72	934	0.79	973	0.86	1010	0.93	1046	1.00	1080	1.07	1113	1.14	1145	1.21	
2200	874	0.76	916	0.83	956	0.91	994	0.98	1031	1.06	1066	1.13	1100	1.21	1133	1.29	1165	1.36	1196	1.44	
2400	943	0.96	982	1.04	1019	1.12	1055	1.21	1090	1.29	1123	1.37	1156	1.45	1187	1.54	1218	1.62	1248	1.70	
2-hp oversized motor and pulley																					

Continued

External Static Pressure (Inches of Water)											
		1.10		1.20		1.30		1.40		1.50	
cfm	rpm	bhp	rpm	bhp	rpm	bhp	rpm	bhp	rpm	bhp	
1-hp standard motor and pulley					2-hp oversized motor and pulley						
1600	1085	0.90	1117	0.96	1149	1.02	1179	1.08	1209	1.15	
1800	1129	1.08	1161	1.14	1191	1.21	1221	1.28	1250	1.35	
2000	1177	1.28	1207	1.35	1237	1.43	1265	1.50	1294	1.58	
2200	1226	1.52	1255	1.60	1284	1.68	1312	1.76	1339	1.84	
2400	1277	1.79	1305	1.87	1333	1.96	1360	2.04	1387	2.13	

Notes:

1. For Standard Evaporator Fan Speed (rpm), reference [Table 24, p. 39](#).
2. For Oversized Evaporator Fan Speed (rpm), reference [Table 25, p. 39](#).
3. 1-hp fan motor heat (MBh) = 2.8328 x Fan bhp. + 0.4714, 2-hp fan motor heat (MBh) = 2.7146 x Fan bhp. + 0.816.
4. Data includes pressure drop due to standard filters and wet coils. No accessories or options are included in pressure drop data.
5. Factory supplied motors, in commercial equipment, are definite purpose motors, specifically designed and tested to operate reliably and continuously at all cataloged conditions. Using the full horsepower range of our fan motors as shown in our tabular data will not result in nuisance tripping or premature motor failure. Our product's warranty will not be affected.

Table 20. Belt drive evaporator fan performance - 5 tons with medium gas heat - GBC060A3, 4, W, K*M - downflow airflow

																						External Static Pressure (Inches of Water)									
		0.10		0.20		0.30		0.40		0.50		0.60		0.70		0.80		0.90		1.00											
cfm	rpm	bhp	rpm	bhp	rpm	bhp	rpm	bhp	rpm	bhp	rpm	bhp	rpm	bhp	rpm	bhp	rpm	bhp	rpm	bhp											
1-hp standard motor and pulley																															
1600	---	---	742	0.40	789	0.45	834	0.51	877	0.56	917	0.62	956	0.68	992	0.74	1028	0.80	1062	0.86											
1800	760	0.47	807	0.53	851	0.59	893	0.65	933	0.71	972	0.78	1008	0.84	1044	0.91	1078	0.97	1111	1.04											
2000	830	0.62	873	0.69	915	0.76	954	0.82	992	0.89	1028	0.96	1063	1.03	1097	1.10	1130	1.17	1161	1.25											
2200	900	0.80	940	0.88	979	0.95	1016	1.03	1052	1.10	1086	1.18	1120	1.26	1152	1.33	1183	1.41	1214	1.49											
2400	970	1.02	1008	1.10	1044	1.18	1079	1.26	1113	1.34	1146	1.43	1178	1.51	1209	1.59	1239	1.68	1268	1.76											
2-hp oversized motor and pulley																															

Continued

												External Static Pressure (Inches of Water)				
		1.10		1.20		1.30		1.40		1.50						
cfm	rpm	bhp	rpm	bhp	rpm	bhp	rpm	bhp	rpm	bhp						
1-hp standard motor and pulley		2-hp oversized motor and pulley														
1600	1095	0.92	1127	0.98	1158	1.04	1188	1.10	1218	1.17						
1800	1143	1.10	1174	1.17	1204	1.24	1233	1.31	1262	1.38						
2000	1192	1.32	1222	1.39	1251	1.47	1280	1.54	1308	1.62						
2200	1244	1.57	1273	1.65	1301	1.73	1328	1.81	1355	1.89						
2400	1297	1.85	1325	1.93	1352	2.02	1379	2.10	1405	2.19						

Notes:

1. For Standard Evaporator Fan Speed (rpm), reference [Table 24, p. 39](#).
2. For Oversized Evaporator Fan Speed (rpm), reference [Table 25, p. 39](#).
3. 1-hp fan motor heat (MBh) = 2.8328 x Fan bhp. + 0.4714, 2-hp fan motor heat (MBh) = 2.7146 x Fan bhp. + 0.816.
4. Data includes pressure drop due to standard filters and wet coils. No accessories or options are included in pressure drop data.
5. Factory supplied motors, in commercial equipment, are definite purpose motors, specifically designed and tested to operate reliably and continuously at all cataloged conditions. Using the full horsepower range of our fan motors as shown in our tabular data will not result in nuisance tripping or premature motor failure. Our product's warranty will not be affected.



Performance Data

Table 21. Belt drive evaporator fan performance - 5 tons with low gas heat - GBC060A3, 4, W, K*L - downflow airflow

																						External Static Pressure (Inches of Water)																			
		0.10		0.20		0.30		0.40		0.50		0.60		0.70		0.80		0.90		1.00																					
cfm	rpm	bhp	rpm	bhp	rpm	bhp	rpm	bhp	rpm	bhp	rpm	bhp	rpm	bhp	rpm	bhp	rpm	bhp	rpm	bhp																					
1-hp standard motor and pulley																																									
1600	---	---	721	0.38	770	0.43	816	0.49	860	0.54	901	0.60	940	0.65	978	0.71	1014	0.77	1048	0.83																					
1800	734	0.44	783	0.50	828	0.56	872	0.62	913	0.68	952	0.74	989	0.81	1025	0.87	1060	0.94	1094	1.00																					
2000	800	0.58	845	0.64	888	0.71	929	0.78	968	0.85	1005	0.92	1041	0.99	1075	1.06	1109	1.13	1141	1.20																					
2200	867	0.74	909	0.82	949	0.89	987	0.97	1024	1.04	1060	1.12	1094	1.20	1127	1.27	1159	1.35	1190	1.43																					
2400	933	0.94	973	1.02	1010	1.10	1047	1.19	1082	1.27	1116	1.35	1148	1.43	1180	1.52	1211	1.60	1241	1.68																					
2-hp oversized motor and pulley																																									

Continued

												External Static Pressure (Inches of Water)									
		1.10		1.20		1.30		1.40		1.50											
cfm	rpm	bhp	rpm	bhp	rpm	bhp	rpm	bhp	rpm	bhp	rpm	bhp	rpm	bhp	rpm	bhp	rpm	bhp	rpm	bhp	
1-hp standard motor and pulley						2-hp oversized motor and pulley															
1600	1082	0.89	1114	0.95	1146	1.02	1176	1.08	1206	1.14											
1800	1126	1.07	1158	1.14	1188	1.20	1218	1.27	1247	1.34											
2000	1172	1.27	1203	1.35	1233	1.42	1262	1.49	1290	1.57											
2200	1220	1.50	1250	1.58	1279	1.66	1307	1.74	1334	1.82											
2400	1270	1.77	1299	1.85	1326	1.94	1354	2.02	1380	2.11											

Notes:

1. For Standard Evaporator Fan Speed (rpm), reference [Table 24, p. 39](#).
2. For Oversized Evaporator Fan Speed (rpm), reference [Table 25, p. 39](#).
3. 1-hp fan motor heat (MBh) = 2.8328 x Fan bhp. + 0.4714, 2-hp fan motor heat (MBh) = 2.7146 x Fan bhp. + 0.816.
4. Data includes pressure drop due to standard filters and wet coils. No accessories or options are included in pressure drop data.
5. Factory supplied motors, in commercial equipment, are definite purpose motors, specifically designed and tested to operate reliably and continuously at all cataloged conditions. Using the full horsepower range of our fan motors as shown in our tabular data will not result in nuisance tripping or premature motor failure. Our product's warranty will not be affected.

Table 22. Belt drive evaporator fan performance - 5 tons with medium gas heat - GBC060A3, 4, W, K*M - horizontal airflow

		External Static Pressure (Inches of Water)																				
		0.10		0.20		0.30		0.40		0.50		0.60		0.70		0.80		0.90		1.00		
cfm	rpm	bhp	rpm	bhp	rpm	bhp	rpm	bhp	rpm	bhp	rpm	bhp	rpm	bhp	rpm	bhp	rpm	bhp	rpm	bhp	rpm	bhp
1-hp standard motor and pulley																						
1600	705	0.36	755	0.41	802	0.47	846	0.52	888	0.58	928	0.64	966	0.69	1002	0.75	1037	0.81	1071	0.87		
1800	776	0.49	822	0.55	865	0.61	907	0.67	946	0.74	984	0.80	1020	0.86	1055	0.93	1089	0.99	1121	1.06		
2000	848	0.65	891	0.72	931	0.78	970	0.85	1007	0.92	1043	0.99	1077	1.06	1111	1.13	1143	1.20	1174	1.28		
2200	921	0.84	961	0.92	999	0.99	1035	1.07	1070	1.14	1104	1.22	1137	1.30	1169	1.37	1199	1.45	1229	1.53		
2400	995	1.07	1032	1.15	1067	1.23	1101	1.32	1134	1.40	1167	1.48	1198	1.56	1228	1.65	1258	1.73	1287	1.82		
2-hp oversize motor and pulley																						

Continued

		External Static Pressure (Inches of Water)										
		1.10		1.20		1.30		1.40		1.50		
cfm	rpm	bhp	rpm	bhp	rpm	bhp	rpm	bhp	rpm	bhp	rpm	bhp
2-hp oversize motor and pulley												
1600	1104	0.93	1136	1.00	1167	1.06	1197	1.12	1226	1.19		
1800	1153	1.13	1184	1.19	1214	1.26	1243	1.33	1271	1.40		
2000	1205	1.35	1234	1.42	1263	1.50	1292	1.57	---	---		
2200	1259	1.61	1287	1.69	---	---	---	---	---	---		
2400	---	---	---	---	---	---	---	---	---	---		

Notes:

1. For Standard Evaporator Fan Speed (rpm), reference [Table 24, p. 39](#).
2. For Oversized Evaporator Fan Speed (rpm), reference [Table 25, p. 39](#).
3. 1-hp fan motor heat (MBh) = 2.8328 x Fan bhp. + 0.4714, 2-hp fan motor heat (MBh) = 2.7146 x Fan bhp. + 0.816.
4. Data includes pressure drop due to standard filters and wet coils. No accessories or options are included in pressure drop data.
5. Factory supplied motors, in commercial equipment, are definite purpose motors, specifically designed and tested to operate reliably and continuously at all cataloged conditions. Using the full horsepower range of our fan motors as shown in our tabular data will not result in nuisance tripping or premature motor failure. Our product's warranty will not be affected.



Performance Data

Table 23. Belt drive evaporator fan performance - 5 tons with low gas heat - GBC060A3, 4, W, K*L - horizontal airflow

External Static Pressure (Inches of Water)																					
		0.10		0.20		0.30		0.40		0.50		0.60		0.70		0.80		0.90		1.00	
cfm	rpm	bhp	rpm	bhp	rpm	bhp	rpm	bhp	rpm	bhp	rpm	bhp	rpm	bhp	rpm	bhp	rpm	bhp	rpm	bhp	
1-hp standard motor and pulley																					
1600	706	0.36	749	0.41	796	0.46	841	0.52	883	0.57	923	0.63	961	0.69	998	0.75	1033	0.80	1067	0.86	
1800	768	0.48	815	0.54	859	0.60	900	0.66	940	0.73	978	0.79	1014	0.85	1049	0.92	1083	0.98	1116	1.05	
2000	839	0.63	882	0.70	923	0.77	962	0.84	1000	0.91	1036	0.98	1071	1.05	1104	1.12	1137	1.19	1168	1.26	
2200	911	0.82	951	0.90	990	0.97	1026	1.05	1062	1.12	1096	1.20	1129	1.28	1161	1.35	1192	1.43	1222	1.51	
2400	984	1.05	1021	1.13	1057	1.21	1091	1.29	1125	1.37	1157	1.46	1189	1.54	1219	1.62	1249	1.71	1278	1.79	
2-hp oversized motor and pulley																					

Continued

External Static Pressure (Inches of Water)											
		1.10		1.20		1.30		1.40		1.50	
cfm	rpm	bhp	rpm	bhp	rpm	bhp	rpm	bhp	rpm	bhp	
		1-hp standard motor and pulley		2-hp oversized motor and pulley							
1600	1100	0.93	1132	0.99	1163	1.05	1193	1.11	1222	1.18	
1800	1148	1.11	1179	1.18	1209	1.25	1238	1.32	1266	1.39	
2000	1199	1.33	1229	1.41	1258	1.48	1286	1.56	---	---	
2200	1252	1.59	1280	1.67	1309	1.75	---	---	---	---	
2400	1307	1.88	---	---	---	---	---	---	---	---	

Notes:

1. For Standard Evaporator Fan Speed (rpm), reference [Table 24, p. 39](#).
2. For Oversized Evaporator Fan Speed (rpm), reference [Table 25, p. 39](#).
3. 1-hp fan motor heat (MBh) = 2.8328 x Fan bhp. + 0.4714, 2-hp fan motor heat (MBh) = 2.7146 x Fan bhp. + 0.816.
4. Data includes pressure drop due to standard filters and wet coils. No accessories or options are included in pressure drop data.
5. Factory supplied motors, in commercial equipment, are definite purpose motors, specifically designed and tested to operate reliably and continuously at all cataloged conditions. Using the full horsepower range of our fan motors as shown in our tabular data will not result in nuisance tripping or premature motor failure. Our product's warranty will not be affected.

Table 24. Standard motor and drive/fan speed (rpm)

Tons	Unit Model Number	Fan Sheave	6 Turns Open	5 Turns Open	4 Turns Open	3 Turns Open	2 Turns Open	1 Turn Open	Closed
3	E/GBC036A3,4,W,K	AK59X3/4"	580	639	702	766	830	891	952
4	E/GBC048A3,4,W,K	AK56X3/4"	619	684	748	820	888	948	1003
5	E/GBC060A3,4,W,K	AK49X3/4"	699	775	854	927	991	1058	1115

Note: Factory set at 3 turns open.

Table 25. Oversized motor and drive/fan speed (rpm)

Tons	Unit Model Number	Fan Sheave	6 Turns Open	5 Turns Open	4 Turns Open	3 Turns Open	2 Turns Open	1 Turn Open	Closed
3	E/GBC036A3,4,W,K	AK56X3/4"	N/A	888	954	1018	1084	1147	1211
4	E/GBC048A3,4,W,K	AK51X3/4"	N/A	963	1033	1097	1156	1233	1295
5	E/GBC060A3,4,W,K	AK51X3/4"	N/A	963	1033	1097	1156	1233	1295

Note: Factory set at 3 turns open.

Tested with 2" MERV 13 filters 3-5 tons.

Table 26. Static pressure drop through accessories (inches water column) - 3 to 5 tons

Tons	Unit Model Number	cfm	Standard Filters ^(a)	2-in. MERV 13 Filters ^(b)	Economizer with OA/RA Dampers ^(c)				Low Leak Economizer				Electric Heater Accessory (kW) ^(d)	
					100% OA	100% RA	100% OA	100% RA	100% OA	100% RA	100% OA	100% RA	5-15	20-25
					Downflow		Horizontal		Downflow		Horizontal			
3	E/GBC036A*	960	0.01	0.08	0.04	0.01	0.04	0.01	0.07	0.07	0.03	0.08	0.01	0.01
		1200	0.02	0.10	0.06	0.01	0.06	0.01	0.10	0.10	0.04	0.11	0.02	0.02
		1440	0.03	0.12	0.08	0.02	0.08	0.01	0.14	0.15	0.05	0.15	0.02	0.03
4	E/GBC048A*	1280	0.03	0.11	0.09	0.02	0.09	0.01	0.11	0.12	0.04	0.12	0.02	0.03
		1600	0.04	0.14	0.13	0.04	0.13	0.02	0.17	0.18	0.06	0.15	0.04	0.05
		1920	0.06	0.16	0.17	0.06	0.17	0.02	0.24	0.26	0.09	0.11	0.05	0.08
5	E/GBC060A*	1600	0.04	0.14	0.13	0.04	0.13	0.02	0.17	0.18	0.06	0.19	0.04	0.05
		2000	0.06	0.17	0.18	0.07	0.18	0.02	0.25	0.27	0.09	0.29	0.06	0.08
		2400	0.08	0.20	0.25	0.11	0.25	0.03	0.36	0.38	0.13	0.40	0.08	0.12

(a) Tested with 2-in. standard filters.

(b) Tested with 2-in. MERV 13 filters 3–5 tons.

(c) OA = Outside Air and RA = Return Air.

(d) Nominal kW ratings at 240, 480, 600 volts.



Performance Data

Table 27. Gas fired heating capacities

Tons	Unit Model Number	Heating Input (MBH) ^(a)	Heating Output (MBH) ^(a)	Air Temp Rise (F)
3	GBC036A(3,4,W)E(L or X)	72	58	30 - 60
	GBC036A(3,4,W)E(M or Y)	100 / 80	80 / 64	50 - 80
4	GBC048A(3,4,W)E(L or X)	72	58	25 - 60
	GBC048A(3,4,W)E(M or Y)	115 / 92	92 / 74	50 - 80
5	GBC060A(3,4,W)E(L or X)	72	58	20 - 60
	GBC060A(3,4,W)E(M or Y)	115 / 92	92 / 74	35 - 65

(a) For two stage heaters (input or output), second stage is total heating capacity. Second stage / first stage.

Table 28. Auxiliary electric heat capacity

Tons	Unit Model Number	Total ^(a)		No. of Stages	Stage1		Stage 2	
		kW Input ^(b)	MBh Output		kW Input	MBh Output	kW Input	MBh Output
3	EBC036A*	4.7	16.05	1	4.7	16.05	-	-
		7.5	25.61	1	7.5	25.61	-	-
		10	34.14	1	10	34.14	-	-
		14.4	49.16	1	14.4	49.16	-	-
4	EBC048A*	4.7	16.05	1	4.7	16.05	-	-
		7.5	25.61	1	7.5	25.61	-	-
		10	34.14	1	10	34.14	-	-
		14.4	49.16	1	14.4	49.16	-	-
		20	68.28	2	10	34.14	10	34.14
5	EBC060A*	4.7	16.05	1	4.7	16.05	-	-
		7.5	25.61	1	7.5	25.61	-	-
		10	34.14	1	10	34.14	-	-
		14.4	49.16	1	14.4	49.16	-	-
		20	68.28	2	10	34.14	10	34.14
		25	85.35	2	12.5	42.68	12.5	42.68

(a) Heaters are rated at 240V, 480V, and 600V. For other than rated voltage, CAP = (voltage/rated voltage)² x rated cap.

(b) For all input/output categories, does not include fan power or heat.

Table 29. Electric heater voltage correction factors (applicable to auxiliary heat capacity)

Nominal Voltage	Distribution Voltage	Capacity Multiplier
240	187	0.61
	208	0.75
	230	0.92
	240	1.00
	253	1.11
480	440	0.84
	460	0.92
	480	1.00
	506	1.11
600	540	0.81
	575	0.92
	600	1.00

Table 30. Air temperature rise across electric heaters (°F)

kW	Stages	3 Tons 940 CFM EBC036A*	4 Tons 1280 CFM EBC048A*	5 Tons 1640 CFM EBC060A*
4.7	1	12.38	9.29	7.43
7.5	1	19.76	14.82	11.85
10	1	26.34	19.76	15.81
14.4	1	37.93	28.45	22.76
20	2	-	39.51	31.61
25	2	-	-	39.51

Notes:

1. For minimum design airflow, see airflow performance table for each unit.
2. To calculate temp rise at different airflow, use the following formula:
Temp. rise across Electric Heater = kW x 3414/1.08 x cfm.



Controls

Economizer Controls

The standard equipment offering is a fixed dry bulb changeover control. In addition, there are two optional controls, Reference Enthalpy Control and Comparative Enthalpy Control.

Reference Enthalpy Control

Replaces the dry bulb control with a wet bulb changeover controller which has a fully adjustable setpoint. Enthalpy control offers a higher level of comfort control, along with energy savings potential, than the standard dry bulb control. This is due to the additional wet bulb sensing capability.

Comparative Enthalpy Control

Comparative Enthalpy replaces the standard dry bulb control with two sensors that compare total heat content of the indoor air and outdoor air to determine the most efficient air source. This control option offers the highest level of comfort control, plus energy efficiency, available.

Remote Potentiometer

Minimum position setting of economizer can be remotely adjusted with this accessory.

Thermostats

Non-Programmable Thermostat

*TCONT402*** (3H/2C)*

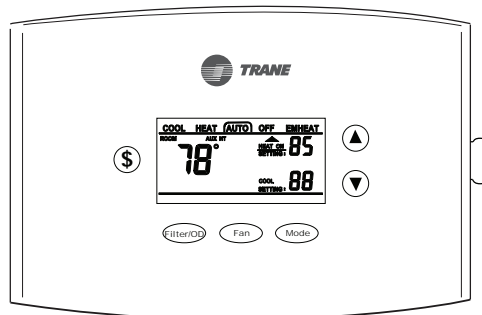

- Three heat/Two cool
- Auto-changeover
- Backlit Display & Keys
- Filter Reminder
- Keypad Lock
- Outdoor Temp Sensor Included

Programmable Thermostat

*TCONT802*** (3H/2C)*

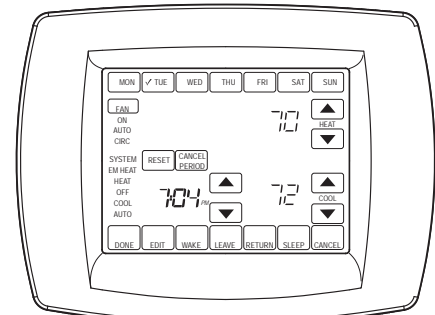

- Three heat/Two cool
- Interactive touchscreen
- Large display
- Real time clock



Electrical Data

Table 31. Unit wiring with cooling (no electric heat) or gas heat

Tons	Unit Model Number	Unit Operating Voltage Range	Standard Indoor Fan Motor		Oversized Indoor Fan Motor	
			Minimum Circuit Ampacity ^(a)	Maximum Fuse Size or Maximum Circuit Breaker	Minimum Circuit Ampacity	Maximum Fuse Size or Maximum Circuit Breaker
3	E/GBC036A3	208-230	20	25	21	30
	E/GBC036A4	460	11	15	12	15
	E/GBC036AW	575	7	15	8	15
	E/GBC036AK	380 ^(b)	11	15	12	15
4	E/GBC048A3	208-230	24	35	25	35
	E/GBC048A4	460	11	15	12	15
	E/GBC048AW	575	9	15	10	15
	E/GBC048AK	380 ^(b)	14	20	15	20
5	E/GBC060A3	208-230	27	40	28	40
	E/GBC060A4	460	13	20	14	20
	E/GBC060AW	575	10	15	11	15
	E/GBC060AK	380 ^(b)	14	20	16	20

(a) For Standard and Oversized Indoor Fan Motor, values do not include power exhaust accessory.
 (b) Unit will operate reliably at 400VAC.

Table 32. Unit wiring with electric heat (single point connection)

Tons	Unit Model Number	Heater Model Number	Heater kW Rating ^(a)	Control Stages	Heater Amps	Standard Indoor Motor		Oversized Indoor Motor	
						MCA	Max Fuse Size or Max Circuit Breaker	MCA	Max Fuse Size or Max Circuit Breaker ^(b)
208/230 Volts Three Phase									
3	EBC036A3	BAYHTFA305A	3.5/4.7	1	9.7/11.3	20/21	25/25	21/22	30/30
		BAYHTFA307A	5.6/7.5	1	15.6/18.1	26/29	30/30	28/31	30/35
		BAYHTFA310A	7.5/10.0	1	20.8/24.1	33/37	35/40	34/38	35/40
		BAYHTFA315A	10.8/14.4	1	30.0/34.7	44/50	45/50	46/51	50/60
4	EBC048A3	BAYHTFA305A	3.5/4.7	1	9.7/11.3	24/24	35/35	25/25	35/35
		BAYHTFA307A	5.6/7.5	1	15.6/18.1	26/29	35/35	28/31	35/35
		BAYHTFA310A	7.5/10.0	1	20.8/24.1	33/37	35/40	34/38	35/40
		BAYHTFA315A	10.8/14.4	1	30.0/34.7	44/50	45/50	46/51	50/60
		BAYHTFA320A	15.0/20.0	2	41.7/48.2	59/67	60/70	60/68	60/70
5	EBC060A3	BAYHTFA305A	3.5/4.7	1	9.7/11.3	27/27	40/40	28/28	40/40
		BAYHTFA307A	5.6/7.5	1	15.6/18.1	27/29	40/40	28/31	40/40
		BAYHTFA310A	7.5/10.0	1	20.8/24.1	33/37	40/40	34/38	40/40
		BAYHTFA315A	10.8/14.4	1	30.0/34.7	44/50	45/50	46/51	50/60
		BAYHTFA320A	15.0/20.0	2	41.7/48.2	59/67	60/70	60/68	60/70
		BAYHTFA325A	18.8/25.0	2	52.2/60.2	72/82	80/90	73/83	80/90



Electrical Data

Table 32. Unit wiring with electric heat (single point connection) (continued)

Tons	Unit Model Number	Heater Model Number	Heater kW Rating ^(a)	Control Stages	Heater Amps	Standard Indoor Motor		Oversized Indoor Motor	
						MCA	Max Fuse Size or Max Circuit Breaker	MCA	Max Fuse Size or Max Circuit Breaker ^(b)
460 Volts Three Phase									
3	EBC036A4	BAYHTFA405A	4.7	1	5.7	11	15	12	15
		BAYHTFA407A	7.5	1	9.0	15	15	16	20
		BAYHTFA410A	10.0	1	12.0	19	20	19	20
		BAYHTFA415A	14.4	1	17.3	25	25	26	30
4	EBC048A4	BAYHTFA405A	4.7	1	5.7	11	15	12	15
		BAYHTFA407A	7.5	1	9.0	15	15	16	20
		BAYHTFA410A	10.0	1	12.0	19	20	19	20
		BAYHTFA415A	14.4	1	17.3	25	25	26	30
		BAYHTFA420A	20.0	2	24.1	34	35	34	35
5	EBC060A4	BAYHTFA405A	4.7	1	5.7	13	20	14	20
		BAYHTFA407A	7.5	1	9.0	15	20	16	20
		BAYHTFA410A	10.0	1	12.0	19	20	19	20
		BAYHTFA415A	14.4	1	17.3	25	25	26	30
		BAYHTFA420A	20.0	2	24.1	34	35	34	35
		BAYHTFA425A	25.0	2	30.1	41	45	42	45
575 Volts Three Phase									
3	EBC036AW	BAYHTFAW10A	10.0	1	9.6	15	15	16	20
		BAYHTFAW15A	14.4	1	13.9	20	20	21	25
4	EBC048AW	BAYHTFAW10A	10.0	1	9.6	15	15	16	20
		BAYHTFAW15A	14.4	1	13.9	20	20	21	25
		BAYHTFAW20A	20.0	2	19.3	27	30	28	30
5	EBC060AW	BAYHTFAW10A	10.0	1	9.6	15	15	16	20
		BAYHTFAW15A	14.4	1	13.9	20	20	21	25
		BAYHTFAW20A	20.0	2	19.3	27	30	28	30
		BAYHTFAW25A	25.0	2	24.1	33	35	34	35
380 Volts Three Phase^(c)									
3	EBC036AK	BAYHTFA407A	4.7	1	7.1	12	15	14	15
		BAYHTFA410A	6.3	1	9.6	15	15	17	20
		BAYHTFA415A	9.0	1	13.7	20	20	22	25
4	EBC048AK	BAYHTFA407A	4.7	1	7.1	14	20	15	20
		BAYHTFA410A	6.3	1	9.6	15	20	17	20
		BAYHTFA415A	9.0	1	13.7	20	20	22	25
		BAYHTFA420A	12.5	2	19.0	27	30	29	30
5	EBC060AK	BAYHTFA407A	4.7	1	7.1	14	20	16	20
		BAYHTFA410A	6.3	1	9.6	15	20	17	20
		BAYHTFA415A	9.0	1	13.7	20	20	22	25
		BAYHTFA420A	12.5	2	19.0	27	30	29	30
		BAYHTFA425A	15.7	2	23.9	33	35	35	35

(a) Heater kW ratings are at 208/240V for 208/230V units, 480V for 380V & 460V units, and 600V for 575V units.

(b) Values do not include power exhaust accessory.

(c) Unit will operate reliably at 400VAC.

Table 33. Electrical characteristics—compressor motor and condenser motor

Tons	Unit	Volts	Compressor Motors						Condenser Fan Motors				
			No.	Phase	HP	RPM	Amps ^(a)		No.	Phase	HP	Amps ^(a)	
	Model No.						RLA	LRA				FLA	LRA
3	E/GBC036A3	208-230	1	3	4.1	3500	10.4	73	1	3	0.33	1.4	4.6
	E/GBC036AK	380 ^(b)	1	3	4.1	3500	5.7	45	1	3	0.33	0.85	3.1
	E/GBC036A4	460	1	3	4.1	3500	5.8	38	1	3	0.33	0.7	2.3
	EBC036AW	575	1	3	4.12	3500	3.8	36	1	3	0.33	0.55	1.8
4	E/GBC048A3	208-230	1	3	5.39	3500	13.7	83	1	3	0.33	1.4	4.6
	E/GBC048AK	380 ^(b)	1	3	5.44	3500	8.1	56	1	3	0.33	0.85	3.1
	E/GBC048A4	460	1	3	5.44	3500	6.2	41	1	3	0.33	0.7	2.3
	EBC048AW	575	1	3	5.42	3500	4.8	33	1	3	0.33	0.55	1.8
5	E/GBC060A3	208-230	1	3	6.45	3500	16.0	110	1	3	0.33	1.4	4.6
	E/GBC060AK	380 ^(b)	1	3	6.5	3500	8.5	66	1	3	0.33	0.85	3.1
	E/GBC060A4	460	1	3	6.5	3500	7.8	52	1	3	0.33	0.7	2.3
	EBC060AW	575	1	3	6.5	3500	5.7	39	1	3	0.33	0.55	1.8

(a) For Compressor Motors and Condenser Fan Motors: Amp draw for each motor; multiply value by number of motors to determine total amps.
(b) Unit will operate reliably at 400VAC.

Table 34. Electrical characteristics—evaporator fan motor

Tons	Unit Model Number	Standard Evaporator Fan Motor						Oversized Evaporator Fan Motor					
		No.	Volts	Phase	HP	Amps		No.	Volts	Phase	HP	Amps	
						FLA	LRA					FLA	LRA
3	E/GBC036A3	1	208–230	3	1	5.0	24.5	1	208–230	3	2	6.12	53.6
	E/GBC036AK	1	380 ^(a)	3	1	2.2	14.5	1	380 ^(a)	3	2	3.5	27.8
	E/GBC036A4	1	460	3	1	2.5	12.3	1	460	3	2	3.09	27.2
	EBC036AW	1	575	3	1	1.5	11.3	1	575	3	2	2.4	16.8
4	E/GBC048A3	1	208–230	3	1	5.0	24.5	1	208–230	3	2	6.12	53.6
	E/GBC048AK	1	380 ^(a)	3	1	2.2	14.5	1	380 ^(a)	3	2	3.5	27.8
	E/GBC048A4	1	460	3	1	2.5	12.3	1	460	3	2	3.09	27.2
	EBC048AW	1	575	3	1	1.5	11.3	1	575	3	2	2.4	16.8
5	E/GBC060A3	1	208–230	3	1	5.0	24.5	1	208–230	3	2	6.12	53.6
	E/GBC060AK	1	380 ^(a)	3	1	2.2	14.5	1	380 ^(a)	3	2	3.5	27.8
	E/GBC060A4	1	460	3	1	2.5	12.3	1	460	3	2	3.09	27.2
	EBC060AW	1	575	3	1	1.5	11.3	1	575	3	2	2.4	16.8

(a) Unit will operate reliably at 400Vac.



Electrical Data

Table 35. Electrical characteristics—combustion blower motor (gas heat units)

Unit Model Number	Heat	Heating Stages	hp	rpm	Volts	Phase	Amps	
							FLA	LRA
GBC036-060A	Low	1	1/35	3290	208–230	1	0.21	0.35
	Med	2	1/45	3400	208-230	1	0.15	0.35

Table 36. Electrical characteristics—power exhaust

Tons	Volts	Phase	hp	rpm	Amps	
					FLA	LRA
3-5	208–230	1	0.33	1075	2.2	3.9
	460	1	0.33	1075	1.1	2.0
	575	1	0.33	1075	1.0	1.8

Jobsite Connections

Table 37. Typical number of wires

Thermostats

B 3 Power Wires + 1 Ground Wire (three phase)

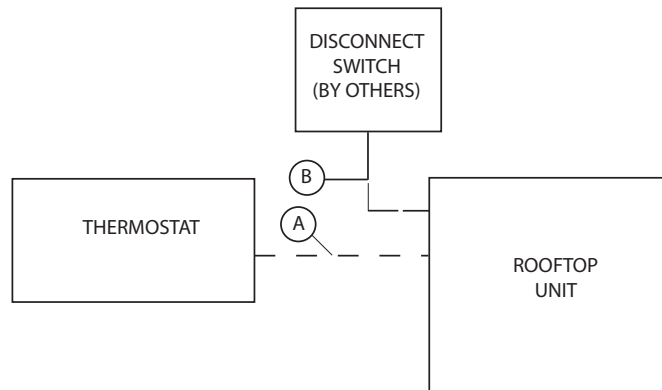

Notes:

- For specific wiring information, see the installation instructions.
- All wiring except power wire is low voltage.
- All customer supplied wiring to be copper and must conform to applicable electrical codes and local electric codes. Wiring shown dotted is to be furnished and installed by the customer.

Dimensional Data

Figure 1. Cooling with optional electrical heat and gas/electric units — overview

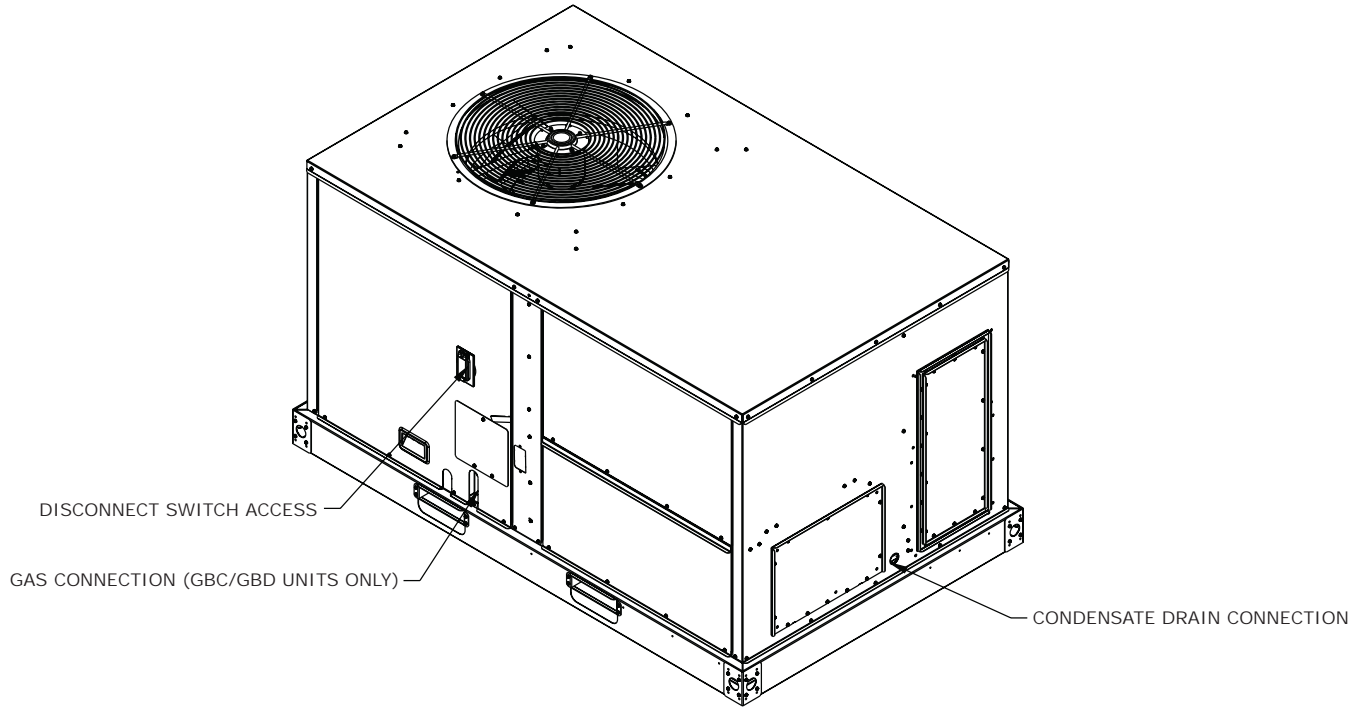
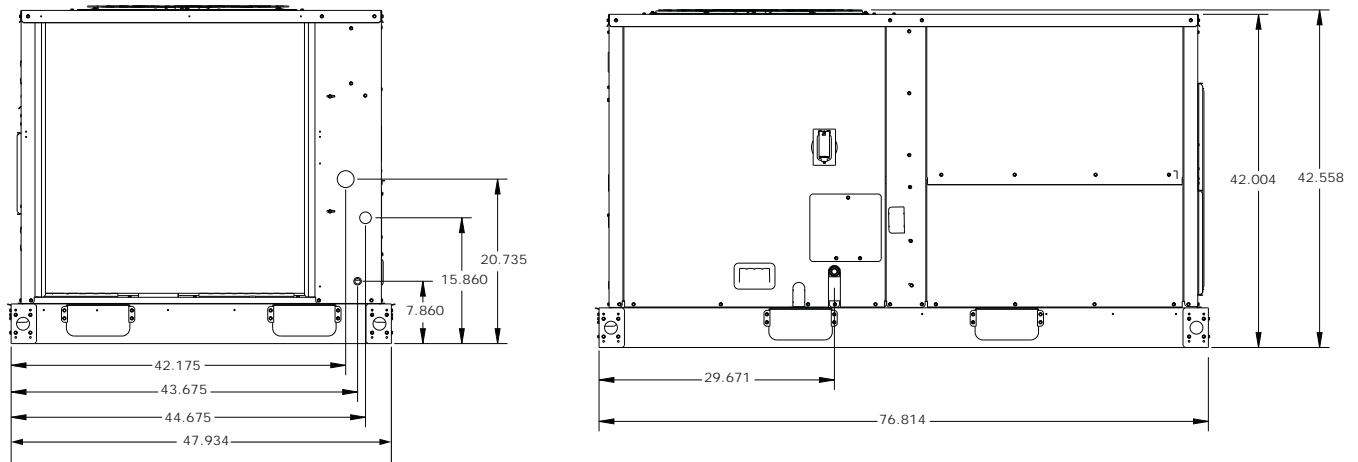

Figure 2. Cooling with optional electrical heat and gas/electric units — front & side views — 3-5 tons



NOTES:

1. THRU-THE-BASE GAS AND ELECTRICAL IS NOT STANDARD ON ALL UNITS.
2. VERIFY WEIGHT, CONNECTION, AND ALL DIMENSION WITH INSTALLER DOCUMENTS BEFORE INSTALLATION.

Figure 3. Cooling with optional electrical heat and gas/electric units — plan view — 3–5 tons

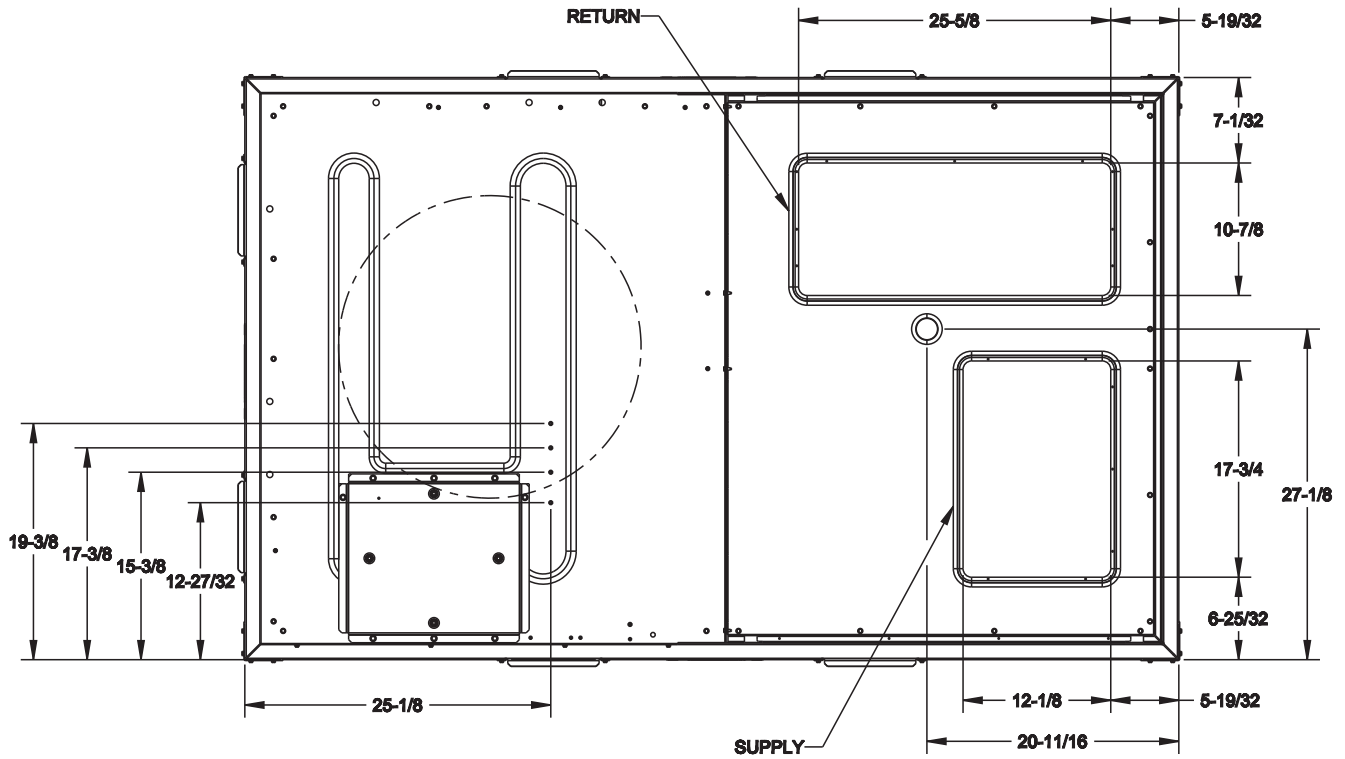
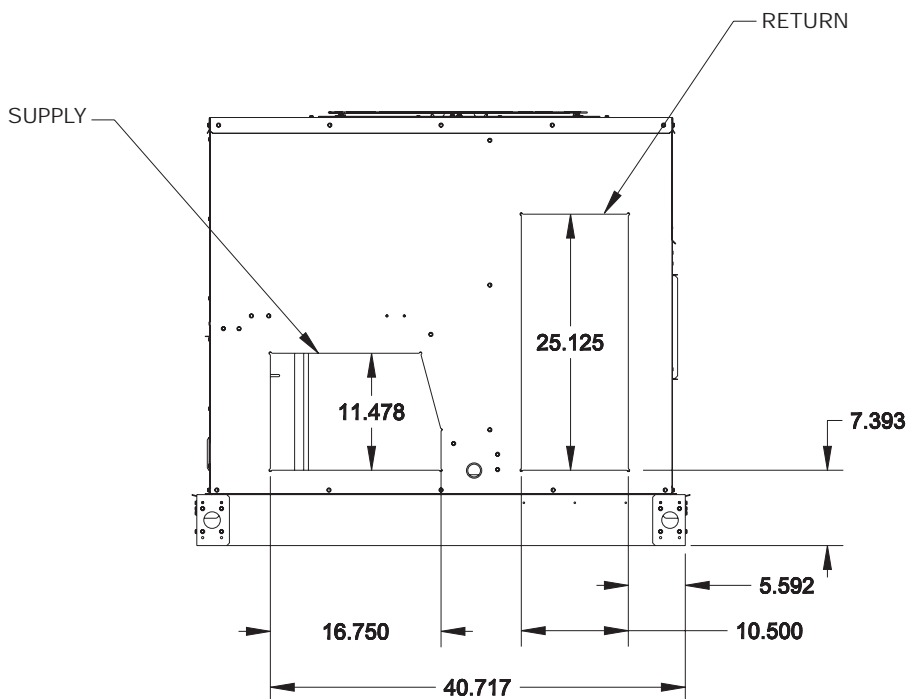

Figure 4. Cooling with optional electrical heat and gas/electric units — back view (horizontal configuration) — 3-5 tons



Dimensional Data

Figure 5. Cooling with optional electric heat and gas/electric models — roof curb — 3-5 tons

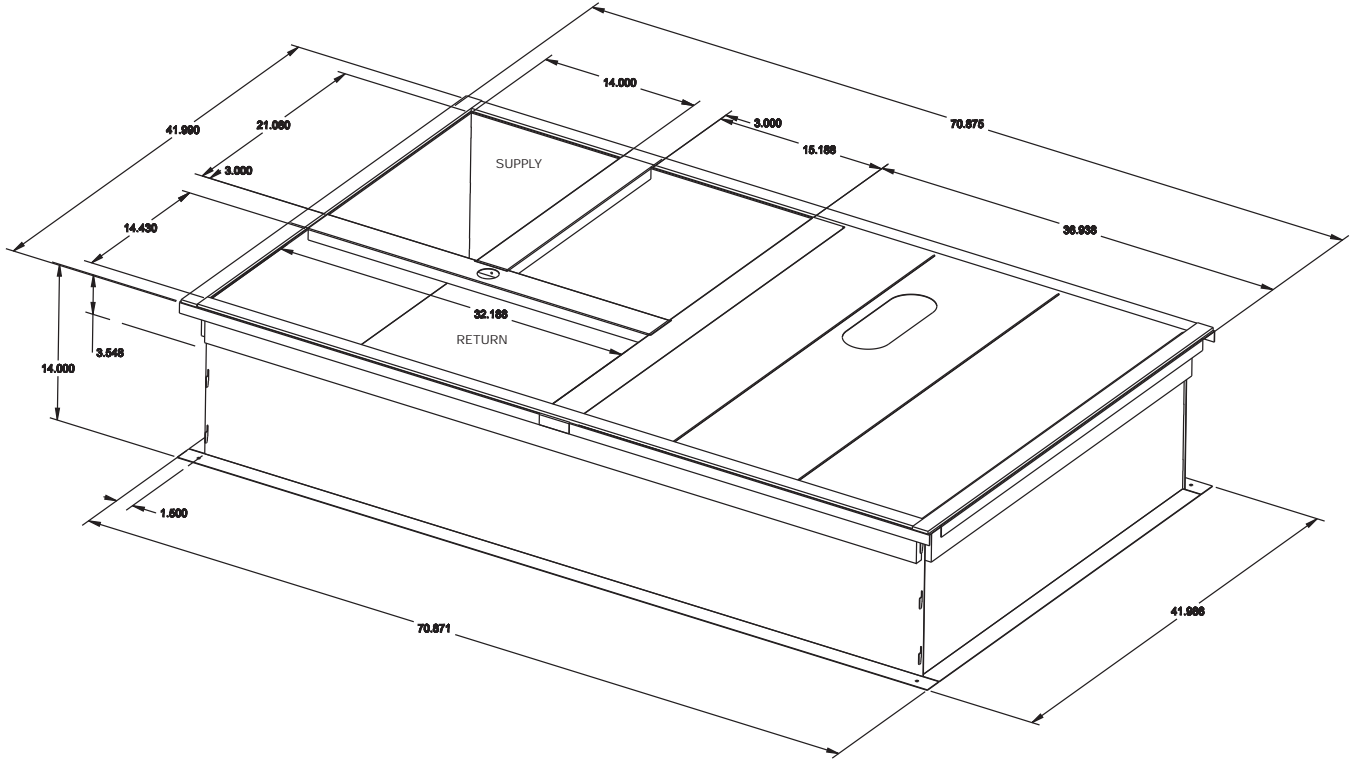

Figure 6. Cooling with optional electric heat and gas/electric models — downflow unit clearance — 15-25 tons

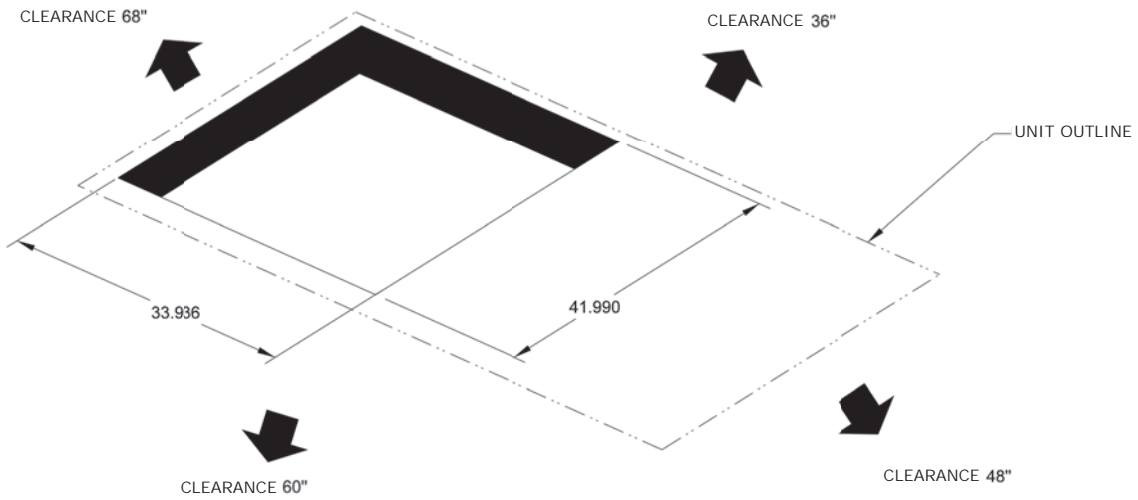

Figure 7. Cooling with optional electric heat and gas/electric models — barometric relief and economizer— 3-5 tons

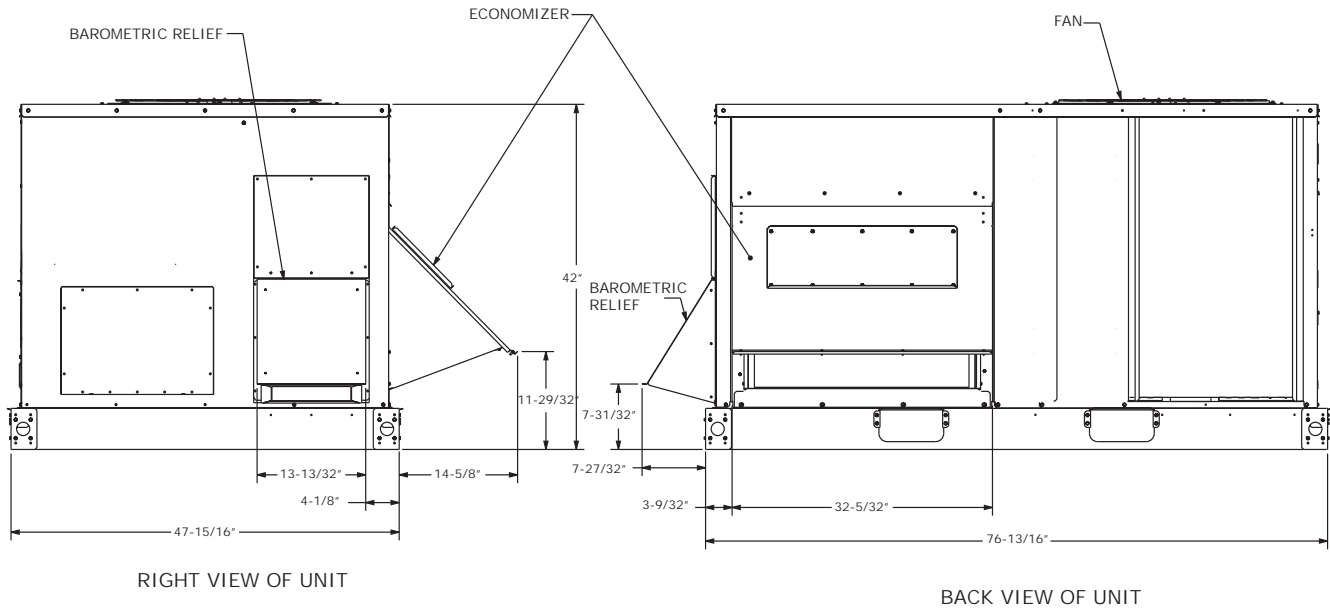
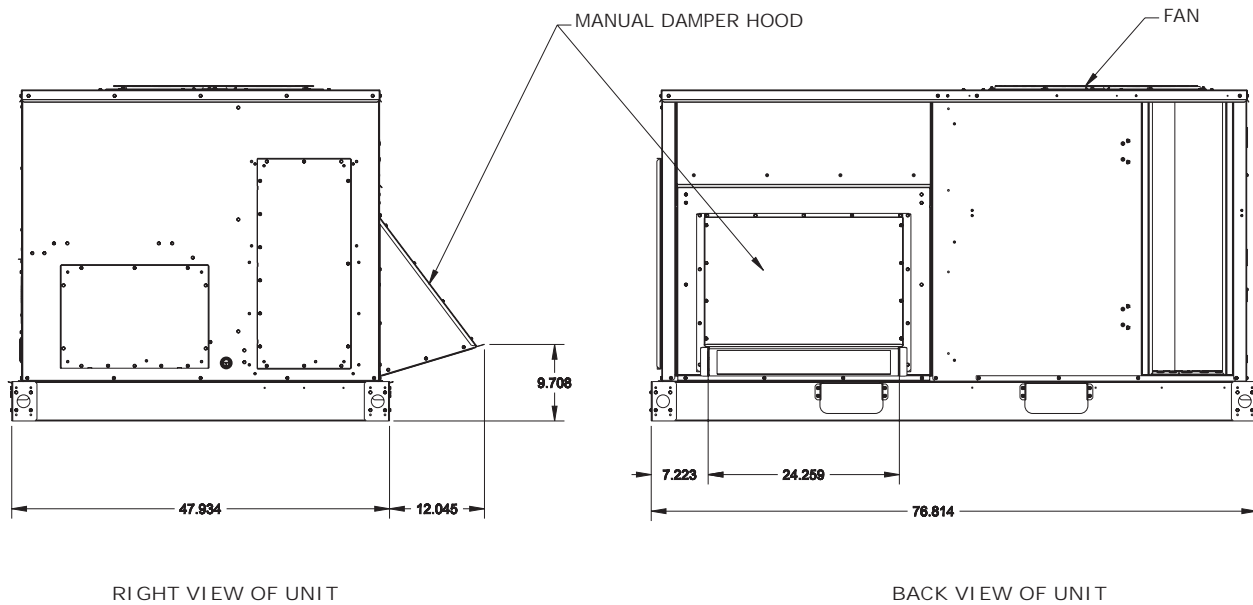

Figure 8. Cooling with optional electric heat and gas/electric models — manual damper — 3-5 tons



NOTE:
 VERIFY WEIGHT, CONNECTION, AND ALL
 DIMENSIONS WIT INSTALLER DOCUMENTS BEFORE
 INSTALLATION.

Weights

Table 38. Maximum unit & corner weights (lb) and center of gravity dimensions (in.) cooling with optional electric heat units only

Tons	Unit Model No.	Weights (lb) ^{(a), (b)}		Corner Weights ^(c)				Center of Gravity (in.)	
		Shipping	Net	A	B	C	D	Length	Width
3	EBC036*	523	473	87	98	153	135	41	29
	GBC036*	574	524	95	111	172	146	42	29
4	EBC048*	566	516	103	107	155	150	39	28
	GBC048*	616	566	110	119	175	162	40	29
5	EBC060*	586	536	112	112	156	156	38	28
	GBC060*	636	586	120	125	174	168	39	28

(a) Weights are approximate.

(b) Weights do not include additional factory or field installed options/accessories. For option/accessory additional weights, reference [Table 39, p. 53](#) to be added to unit weights.

(c) Corner weights are given for information only.

Figure 9. Center of gravity - 3-5 tons

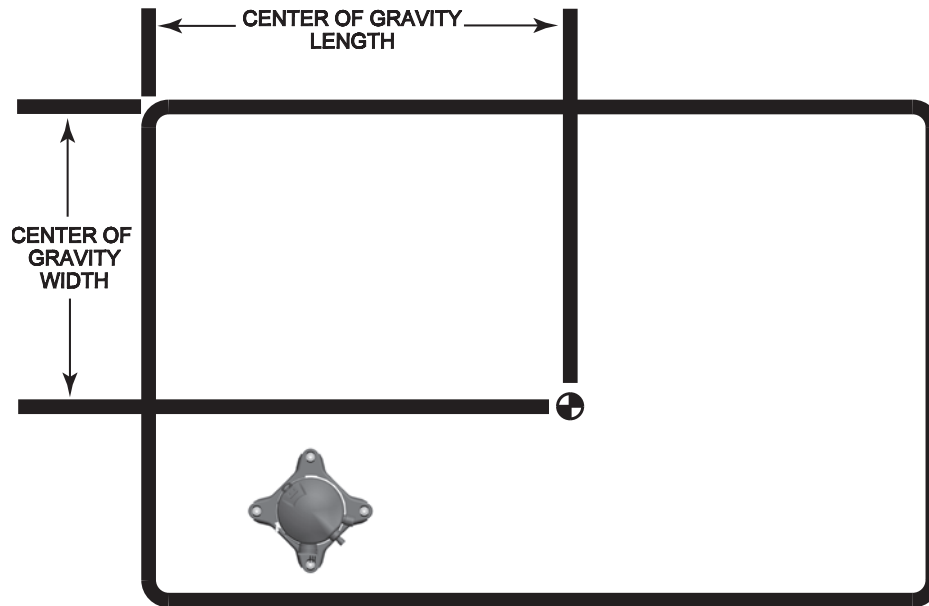

Table 39. Accessory net weight (lb)^(a), (b), (c)

Accessories	E/GBC036-060
Standard Economizer	26
Low Leak Economizer	68
Manual Outside Air Damper	16
Motorized outside Air Damper ^(d)	20
Power Exhaust ^(d)	40
Barometric relief ^(d)	7
Roof Curb ^(d)	61
Oversized Motor	5
Hail Guard	12
Through the Base Electrical	8
Disconnect	5
Electric Heaters ^(e)	15

(a) Net weight should be added to unit weight when ordering factory-installed accessories.

(b) Weights for factory installed options and field installed accessories not listed are < 5 lb.

(c) To estimate shipping weight add 5 lb to net weight.

(d) Downflow only.

(e) For 600V heaters net weights are same as 480V heaters.



Mechanical Specifications

General

The units shall be dedicated downflow or horizontal airflow. The operating range shall be between 125°F and 45°F in cooling as standard from the factory for all units. Cooling performance shall be rated in accordance with AHRI testing procedures. All units shall be factory assembled, internally wired, fully charged with R-410A, and 100 percent run tested to check cooling operation, fan and blower rotation and control sequence, before leaving the factory. Wiring internal to the unit shall be colored and numbered for simplified identification. Units shall be UL listed and labeled, classified in accordance to UL 1995/C 22.2, 236.

Cooling capacities and efficiencies for Unitary Air-Cooled Packaged Air-conditioners are rated within the scope of the Air-Conditioning, Heating & Refrigeration Institute (AHRI) Certification Program and display the AHRI Certified® mark as a visual confirmation of conformance to the certification sections of AHRI Standard 210-240 (I-P) and ANSIZ21.47 and 10 CFR Part 431 pertaining to Commercial Warm Air Furnaces.

Casing

Unit casing shall be constructed of zinc coated, heavy gauge, galvanized steel. Exterior surfaces shall be cleaned, phosphatized, and finished with a weather-resistant baked enamel finish. Unit's surface shall be tested 672 hours in a salt spray test in compliance with ASTM B117. Cabinet construction shall allow for all maintenance on one side of the unit. In order to ensure a water and air tight seal, service panels shall have lifting handles and no more than four screws to remove. All exposed vertical panels and top covers in the indoor air section shall be insulated with a 1/2-inch, 1-pound density foil-faced, fire-resistant, permanent, odorless, glass fiber material. The base of the downflow unit shall be insulated with 1/2-inch, 1-pound density foil-faced, closed-cell material. The downflow unit's base pan shall have no penetrations within the perimeter of the curb other than the raised 1 1/8-inch high supply/return openings to provide an added water integrity precaution, if the condensate drain backs up. The base of the unit shall have provisions for forklift and crane lifting.

Compressors

All units shall have direct-drive, hermetic, scroll type compressors with centrifugal type oil pumps. Motor shall be suction gas-cooled and shall have a voltage utilization range of plus or minus 10 percent of nameplate voltage. Internal overloads shall be provided with the scroll compressors. All models shall have phase monitors, Low Pressure Controls, High Pressure Controls and Locking Safety Device as Standard.

Controls

Unit shall be completely factory wired with necessary controls and contactor pressure lugs or terminal block for power wiring. Unit shall provide an external location for mounting a fused disconnect device.

Discharge Line Thermostat

A bi-metal element discharge line thermostat is installed as a standard option on the discharge line of each system. This standard option provides extra protection to the compressors against high discharge temperatures in case of loss of charge, extremely high ambient and other conditions which could drive the discharge temperature higher. Discharge line thermostat is wired in series with high pressure control. When the discharge temperature rises above the protection limit, the bi-metal disc in the thermostat switches to the off position, opening the 24 Vac circuit. When the temperature on the discharge line cools down, the bi-metal disc closes the contactor circuit, providing power to the compressor.

Evaporator and Condenser Coils

Microchannel coils will be burst tested by the manufacturer. Microchannel condenser and evaporator coils shall be standard on all units. Coils shall be leak tested to ensure the pressure

integrity. The evaporator coil and condenser coil shall be leak tested to 225 psig and pressure tested to 450 psig. Sloped condensate drain pans are standard.

Filters

Two inch standard filters shall be factory supplied on all units.

Gas Heating Section

The heating section shall have a tubular heat exchanger design. An induced draft combustion blower shall be used to pull the combustion products through the firing tubes. The heater shall use a direct spark ignition (DSI) system. On initial call for heat, the combustion blower shall purge the heat exchanger for 20 seconds before ignition. After three unsuccessful ignition attempts, the entire heating system shall be locked out until manually reset at the thermostat. Units shall be suitable for use with natural gas or propane (field-installed kit).

For installation in SCAQMD only: This furnace does not meet the 14 ng/J NO_x emission limit requirement of SCAQMD Rule 1111, and thus is subject to a mitigation fee of up to \$450. This furnace is not eligible for the Clean Air Furnace Rebate Program:

"<http://www.CleanAirFurnaceRebate.com>".

High Pressure Control

All units include High Pressure Cutout as standard.

Indoor Fan

Units above shall have belt driven, FC centrifugal fans with adjustable motor sheaves. All motors shall be thermally protected. Oversized motors shall be available for high static application. All indoor fan motors meet the U.S. Energy Policy Act of 1992 (EPACT).

Locking Safety Device

Pressure switch monitoring allows for lockout in a situation where the switch is opened. By monitoring the Y input as well as the pressure switches, advanced decision making can be made to identify situations where faults/errors occur.

Low Pressure Control

All units include low pressure cutout as standard.

Outdoor Fans

The outdoor fan shall be direct-drive, statically and dynamically balanced, draw-through in the vertical discharge position. The fan motor(s) shall be permanently lubricated and shall have built-in thermal overload protection.

Phase Monitor

The Phase Monitor is a three-phase line monitor module that protects against phase loss, phase reversal and phase unbalance. It is intended to protect compressors from reverse rotation. It has an operating input voltage range of 190–600 Vac, and LED indicators for ON and FAULT. There are no field adjustments and the module will automatically reset from a fault condition.

Refrigerant Circuits

Each refrigerant circuit shall have independent thermal expansion valve, service pressure ports, and refrigerant line filter driers factory installed as standard. An area shall be provided for replacement suction line driers.

Unit Top

The top cover shall be double hemmed and gasket sealed to prevent water leakage.

Mechanical Specifications

Factory Installed Options

Complete Coat™ Microchannel Condenser Coil

The cathodic epoxy type electrodisposition coating is formulated for high edge build to a number of different types of heat exchangers. The coating is selected to provide excellent resistance and durability to corrosive effects of alkalis, acids, alcohols, petroleum, seawater, salty air, and other corrosive environments. This coating shall be available on microchannel condenser coils.

Stainless Steel Heat Exchanger

Gas heat exchanger shall be of drum and tube design constructed from a minimum 409 grade stainless steel tubes and 439 stainless steel burners. The stainless steel heat exchanger shall have a 10-year warranty as standard (Gas/Electric only).

Factory or Field Installed Options

Barometric Relief

Designed to be used on downflow Low Leak Economizer units, barometric relief is an un-powered means of relieving excess building pressure.

Condensate Overflow Switch

This option shall shut the unit down in the event that a clogged condensate drain line prevents proper condensate removal from the unit.

Economizer (Standard) – Downflow

The assembly includes fully modulating 0–100% motor and dampers, barometric relief, minimum position setting, preset linkage, wiring harness with plug, fixed dry bulb and spring return actuator. The barometric relief damper shall provide a pressure operated damper that shall be gravity closing and shall prohibit entrance of outside air during the equipment “off” cycle.

Electric Heaters

Electric heat modules shall be available for installation within the basic unit. Electric heater elements shall be constructed of heavy-duty nickel chromium elements internally delta connected for 240 volt, wye connected for 380, 480 and 600 volt. Each heater package shall have automatically reset high limit control operating as line break limits. Power assemblies shall provide single-point connection. Electric heat modules shall be UL listed or CSA certified. If ordering the Through the Base Electrical option with an Electric Heater, the heater must be factory installed.

Low Leak Economizer with Fault Detection & Diagnostics - Downflow

This option shall have outside and return air dampers that do not exceed 3 cfm/ft² at 1.0 in. w.g. and supply 100 percent of the design supply air quantity as outside air. The controller shall have the capability to provide the value of each sensor used in controlling the economizer operation. System status is also indicated for the following conditions:

- Free cooling available
- Economizer enabled
- Compressor enabled
- Heating Enabled
- Mixed air low limit cycle active

The Fault Detection and Diagnostic system detects the following faults:

- Air temperature sensor failure/fault
- Not economizing when conditions indicate system should be economizing
- Economizing when conditions indicate system should not be economizing

- Dampers are not modulating
- Excessive amounts of outside air are being introduced through the economizer

The Fault Detection and Diagnostic system is certified by the California Energy Commission as meeting requirements of California Title 24 120.2(i)1 through 120.2(i)8 in accordance with Section 100(h).

Manual Outside Air Damper

The rain hood and screen shall provide up to 50% outside air.

Motorized Outside Air Dampers

Manually set outdoor air dampers shall provide up to 50% outside air. Once set, outdoor air dampers shall open to set position when indoor fan starts. The damper shall close to the full closed position when indoor fan shuts down.

Oversized Motors

Oversized motors shall be available for high static applications.

Reference or Comparative Enthalpy

Reference Enthalpy is used to measure and communicate outdoor humidity. The unit receives and uses this information to provide improved comfort cooling while using the economizer. Comparative Enthalpy measures and communicates humidity for both outdoor and return air conditions, and return air temperature. The unit receives and uses this information to maximize use of economizer cooling, and to provide maximum occupant comfort control. Reference or Comparative Enthalpy option shall be available when a factory or field installed Downflow Economizer is ordered. This option is available on all models.

Through the Base Electrical with Disconnect Switch

Three-pole, molded case, disconnect switch with provisions for through the base electrical connections are available. The disconnect switch will be installed in the unit in a water tight enclosure with access through a swinging door. Factory wiring will be provided from the switch to the unit high voltage terminal block. The switch will be UL/CSA agency recognized.

Note: *The disconnect switch will be sized per NEC and UL guidelines but will not be used in place of unit overcurrent protection.*

Through the Base Gas Piping

The unit shall include a standard through the base gas provision. This option shall have all piping necessary including, black steel, manual gas shut-off valve, elbows, and union. The manual shutoff valve shall include a 1/8" NPT pressure tap. This assembly will require minor field labor to install (Gas/Electric Only).

Through the Base Utilities Access

An electrical service entrance shall be provided allowing electrical access for both control and main power connections inside the curb and through the base of the unit. Option will allow for field installation of liquid-tight conduit and an external field installed disconnect switch.

Field Installed Options

Barometric Relief

Designed to be used on downflow and horizontal configuration for both standard and low leak economizer units, barometric relief is an unpowered means of relieving excess building pressure.

Crankcase Heaters

These band heaters provide improved compressor reliability by warming the oil to prevent migration during off-cycles or low ambient conditions.

Mechanical Specifications

Demand Control Ventilation with CO₂ Sensor

The CO₂ sensor shall have the ability to monitor the concentration (parts per million, ppm) of CO₂ (Carbon Dioxide) in the air. As the CO₂ concentration changes, the outside air damper modulates to meet the current ventilation needs of the zone.

Economizer—Horizontal

The horizontal economizer shall contain the same features as the downflow economizer with the exception of barometric relief.

Low Ambient Kit

Allows system to operate in cooling below 45 degree by maintaining head pressure by cycling the outdoor fan motor allowing safe system operation without indoor coil icing.

Low Leak Economizer with Fault Detection & Diagnostics - Horizontal

This option shall have outside and return air dampers that do not exceed 3 cfm/ft² at 1.0 in. w.g. and supply 100 percent of the design supply air quantity as outside air. The controller shall have the capability to provide the value of each sensor used in controlling the economizer operation. System status is also indicated for the following conditions:

- Free cooling available
- Economizer enabled
- Compressor enabled
- Heating Enabled
- Mixed air low limit cycle active

The Fault Detection and Diagnostic system detects the following faults:

- Air temperature sensor failure/fault
- Not economizing when conditions indicate system should be economizing
- Economizing when conditions indicate system should not be economizing
- Dampers are not modulating
- Excessive amounts of outside air are being introduced through the economizer

The Fault Detection and Diagnostic system is certified by the California Energy Commission as meeting requirements of California Title 24 120.2(i)1 through 120.2(i)8 in accordance with Section 100(h).

Powered Exhaust

The powered exhaust shall provide exhaust of return air, when using an economizer, to maintain better building pressurization.

Remote Potentiometer

The minimum position setting of the economizer shall be adjusted with this accessory.

Roof Curb—Downflow

The roof curb shall be designed to mate with the downflow unit and provide support and a water tight installation when installed properly. The roof curb design shall allow field-fabricated rectangular supply/return ductwork to be connected directly to the curb. Curb shall be shipped knocked down for field assembly and shall include wood nailer strips.

Tool-less Hail Guards

Tool-less, hail protection quality coil guards are available for condenser coil protection.

Two-Inch Pleated Filters

Two-inch MERV 13 filters shall be available on all models.



Trane - by Trane Technologies (NYSE: TT), a global climate innovator - creates comfortable, energy efficient indoor environments for commercial and residential applications. For more information, please visit trane.com or tranetechnologies.com.

Trane has a policy of continuous product and product data improvement and reserves the right to change design and specifications without notice. We are committed to using environmentally conscious print practices.