



TRANE®

INSTALLATION MANUAL

Mode Selection Box

For TVR Heat Recovery Multi-split System

IMPORTANT NOTE:



Original instructions

Thank you very much for purchasing our air conditioner.

Before using your air conditioner, please read this manual carefully and keep it for future reference.

The figure shown in this manual is for reference only and may be slightly different from the actual product.

⚠ CAUTION

Install the MS box at a location where the refrigerant noise cannot disturb the room occupants.

- To prevent the refrigerant noise from disturbing the people in the room, keep at least 5 m of piping between the occupied room and the MS box. See Figure A.
- If there is no false ceiling in the room, please add sound insulation around the piping between the MS box and the indoor unit, or keep a much longer distance between the MS box and occupied room. See Figure A.

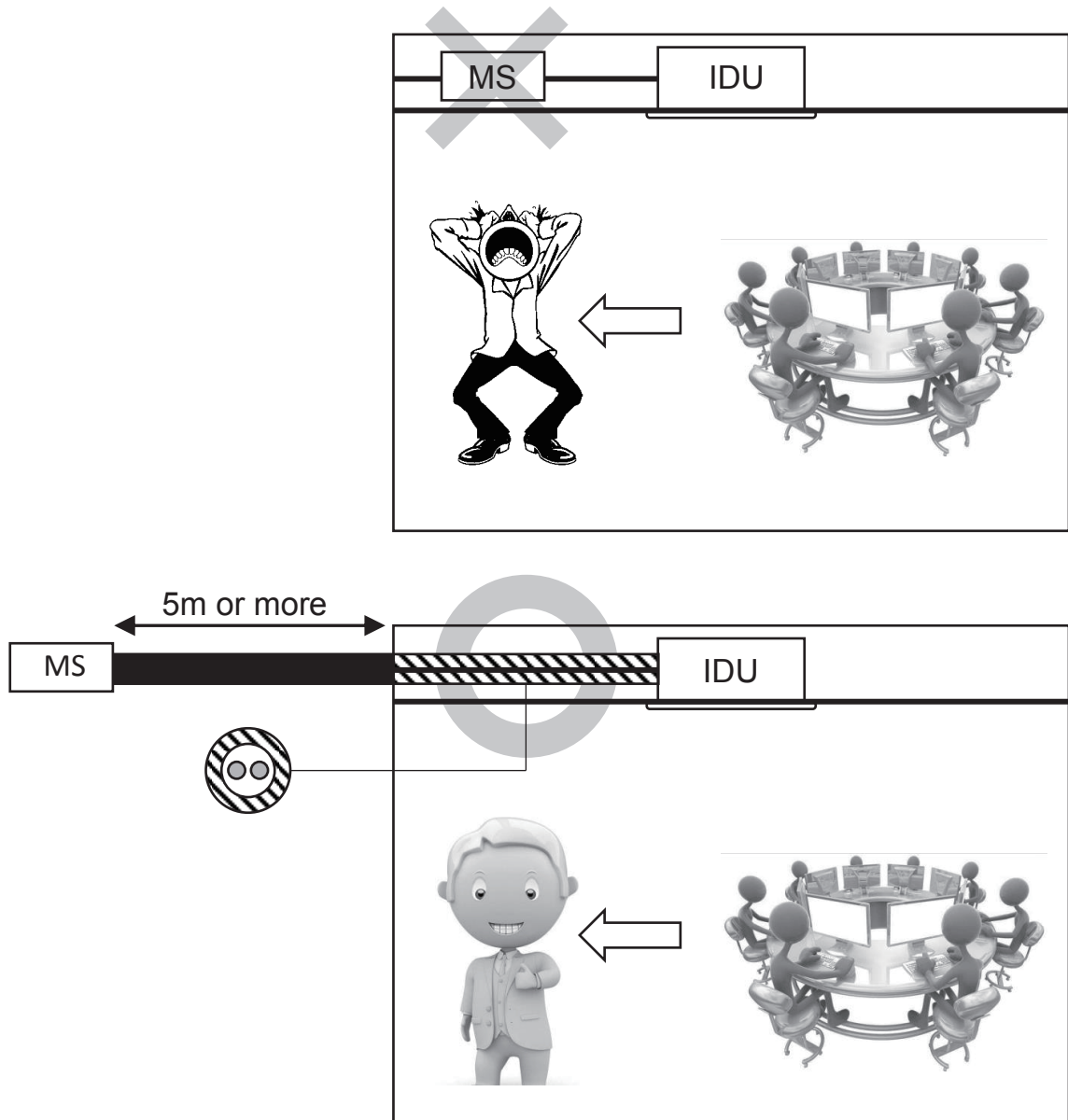

Figure A

CONTENTS

1 SAFETY PRECAUTIONS	1
2 BEFORE INSTALLATION	
• 2.1 Precautions	2
• 2.2 Accessories and locally purchased components	3
• 2.3 Checklist	3
3 INSTALLATION SITE	
• 3.1 The multi MS box	5
• 3.2 The single MS box	6
4 PREPARATIONS BEFORE INSTALLATION	7
5 MS BOX INSTALLATION	
• 5.1 Install the main body	8
• 5.2 The installation of suspension screw bolts	8
• 5.3 Dimension diagrams	9
• 5.4 Hanging the MS box	10
• 5.5 Multiple installations of the single MS box	11
6 REFRIGERANT PIPING	
• 6.1 Range of MS box application	14
• 6.2 Connecting diagram of the multi MS box and indoor unit	14
• 6.3 Connecting diagram of the single MS box and indoor unit	15
• 6.4 Requests for the length of pipes connecting indoor and outdoor units with the MS box and altitude difference	15
• 6.5 Pipe size selection	15
• 6.6 The procedure of connecting pipes	15
• 6.7 Pipeline connection	16
• 6.8 Welding the copper pipe	19
• 6.9 Checking for leakage	20
• 6.10 Airtight test	20
• 6.11 Air purging	20
• 6.12 Open/Close the valves	20
• 6.13 Thermal insulation	20
7 ARRANGEMENTS FOR DRAINAGE PIPE	
• 7.1 Drain pipes installation of the multi MS box	21
• 7.2 Drainage test	21

8 ELECTRIC WIRING

- 8.1 Wiring 22
- 8.2 Wiring for the MS box power wire and signal wire 22
- 8.3 Power specification 22
- 8.4 Wiring requirements for control wire 23
- 8.5 Example of communication wiring 24
- 8.6 Wiring of piping lines and control wires 25

9 INITIAL SETTING

- 9.1 Definition of DIP switches for the single MS box and refrigerant leakage sensor description 26
- 9.2 Dry contact interface connection 27
- 9.3 Definition of DIP switches for the multi MS box models 27
- 9.4 Setting and querying MS box address 27

10 CHARGING ADDITIONAL REFRIGERANT 27

11 QUERY INSTRUCTIONS

- 11.1 SW1/SW2 query instructions 28
 - 11.2 Troubleshooting 29
-

1 SAFETY PRECAUTIONS

- Be sure to be in conformity with the local, national and international laws and regulations.
- Read "SAFETY PRECAUTIONS" carefully before installation.
- The following precautions include important safety items. Always observe these precautions.
- Keep this manual with the owner's manual in a handy place for future reference.
- The model names in the manual are shown in the table below.

Table 1-1

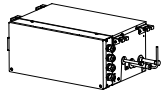
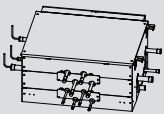
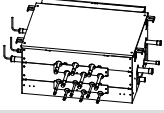
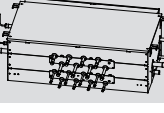
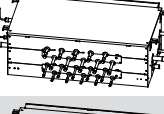
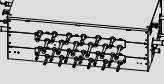
Mode selection box outside drawing	Model name	Abbreviated model name according to the number of ports
	Single MS box	MS01
	Multi MS box	MS04
		MS06
		MS08
		MS10
		MS12

- The A-weighted sound pressure level is below 70 dB.

The safety precautions listed here are divided into two categories. In either case, important safety information which must be read carefully is listed.

WARNING

Indicates a potentially hazardous situation which, if not avoided, could result in death or serious injury.

CAUTION

- Indicates a potentially hazardous situation which, if not avoided, may result in minor or moderate injury.
- It may also be used to alert against unsafe practices.

WARNING

- Ask your local dealer or qualified personnel to carry out installation work. Improper installation may result in water leakage, electric shock, or fire.
- Perform installation work in accordance with the instructions provided in this installation manual. Improper installation may result in water leakage, electric shock, or fire.
- Consult your local dealer regarding what to do in the event of refrigerant leakage. When the MS box is installed in a small room, it is necessary to take proper measures so that the amount of any leaked refrigerant does not exceed the concentration limit in the event of a leakage. Otherwise, this may lead to an accident due to oxygen deficiency.
- Be sure to use only the specified parts and accessories for installation work. Failure to use the specified parts may result in the air conditioner falling down, water leakage, electric shocks, fire, etc.
- Install the MS box on a foundation that can withstand its mass. Insufficient strength may cause the MS box to fall and cause injury. In addition, it may lead to vibration of indoor units and cause an unpleasant chattering noise.
- Carry out the specified installation work in consideration of strong winds, typhoons, or earthquakes. Improper installation may result in an accident such as MS box falling.
- The appliance shall be installed in accordance with national wiring regulations, make sure that all electrical work is carried out by qualified personnel according to the applicable legislation (note 1) and this installation manual, using a separate circuit. In addition, even if the wiring is short, make sure to use wiring that has sufficient length and never connect additional wiring to supplement the length. Insufficient capacity of the power supply circuit or improper electrical construction may lead to electric shock or fire. (note 1) applicable legislation means "All international, national and local directives, laws, regulations and/or codes which are relevant and applicable for a certain product or domain".
- Ground the MS box. Do not connect the ground wiring to gas or water piping, lightning conductor, or telephone ground wiring. Incomplete grounding may cause electric shock or a fire. A high surge current from lightning or other sources may cause damage to the MS box.
- Be sure to install a ground leakage circuit breaker. Failure to do so may cause electric shock and fire.
- Be sure to use only the specified parts and accessories for installation work.
- Disconnect the power supply before touching the electric components.

- Make sure that all wiring is secure, use the specified wiring, and ensure that external forces do not act on the terminal connections or wiring. Incomplete connection or fixing may cause overheating or fire.
- Wiring for power supply and wiring between MS and indoor or outdoor units must be properly laid and formed, and the control box cover must be firmly fastened so that the wiring does not push up structural parts such as the cover.
If the cover is improperly fastened, it may cause electric shock or fire.
- If refrigerant gas leaks during installation, ventilate the area immediately. Toxic gas may be produced if refrigerant gas comes into contact with flame.
- After completing the installation work, check to make sure that there is no leakage of refrigerant gas. Toxic gas may be produced if refrigerant gas leaks into the room and comes into contact with a source of flame, such as a fan heater, stove, or cooker.
- Never directly touch any accidentally leaking refrigerant. This could result in severe wounds due to frostbite.
- This appliance can be used by children aged from 8 years and above and persons with reduced physical, sensory or mental capabilities or lack of experience and knowledge if they have been given supervision or instruction concerning use of the appliance in a safe way and understand the hazards involved. Children shall not play with the appliance. Cleaning and user maintenance shall not be made by children without supervision.

CAUTION

- Install the drain piping according to this installation manual to ensure good drainage, and insulate the piping to prevent condensation.
Improper drain piping may cause water leakage, which could drip onto furniture.
- Install the MS box, power supply wiring, and transmission wiring at least 1 m away from televisions or radios to prevent image interference or noise.
(Depending on the radio waves, a distance of 1 m may not be sufficient to eliminate noise.)
- Install the MS box as far as possible from fluorescent lamps.
If a wireless remote controller kit is installed, the transmission distance may be shorter in a room where an electronic lighting type (inverter or rapid start type) fluorescent lamp is installed.
- Make sure to provide adequate measures to prevent the MS box from being used as a shelter by small animals.
Small animals making contact with electrical parts can cause malfunctions, smoke, or fire. Please instruct the customer to keep the area around the unit clean.

- The MS box is not intended for use in a potentially explosive atmosphere. Do not install the MS box in the following places:
 1. The outside of a building. Rain water can permeate into the MS box and become a cause of electric shock.
 2. Where there is mist of oil, oil spray, or vapour, for example a kitchen. Resin parts may deteriorate, causing them to fall out or water to leak.
 3. Where corrosive gas, such as sulfurous acid gas, is produced. Corrosion of copper piping or brazed parts may cause the refrigerant to leak.
 4. Where there is machinery which emits electromagnetic waves. Electromagnetic waves may disturb the control system, and cause the equipment to malfunction.
 5. Where flammable gases may leak, where carbon fibre or ignitable dust is suspended in the air, or where volatile flammables, such as thinner or gasoline, are handled. If the gas leaks and remains around the MS box, it could ignite.
 6. Do not use in areas where the air is salty, such as along coastlines, in factories, or other areas with significant voltage fluctuations, or in automobiles and watercraft. Doing so could result in a malfunction.
 7. In places that are exposed to wind flow, condensation can gather on the surface of the MS box body, cause leaks.
- Ensure that the electric cable is correctly connected.
If the electric cable is incorrectly connected, then it will damage the electrical components.
- Don't store the unit in a humid basement or expose it to rain or water.

2 BEFORE INSTALLATION

2.1 Precautions

Be sure to verify in advance that the refrigerant used in installation is R410A.

The unit will not operate correctly with a different type of refrigerant.

When moving the unit during or after unpacking, hold it using the 4 hanging brackets and avoid subjecting other parts, particularly refrigerant pipes and the control box, to force.











For more information about the installation of outdoor and indoor units, refer to the installation manual that came with each unit.

2.2 Accessories and locally purchased components

Verify that the following accessories have been included in the packaging.





Accessories of the multi MS box

Table 2-1

NAME	QTY.	SHAPE	USE
Installation & operation manual	1		For the MS box installation and operation instructions
Flexible drainage pipe	2		Connect the drainage port of the MS box and the PVC water pipe.
Snap ring	2		Fasten the connector between the flexible drainage pipe and the MS drainage port.
Adapter pipe (for liquid line)	1		Use for the connection the MS box and the TVR Multi-split Outdoor Unit. (The pipe diameter size is selected based on actual needs) NOTE: The quantity of adapter pipe (for liquid line) of MS08/MS10/MS12 is 2.
	1		
Adapter pipe (for low pressure line)	1		
	1		
Adapter pipe (for high pressure line)	1		
	1		
Build-out resistor	4		To improve communication stability

Accessories of the single MS box

Table 2-2

NAME	QTY.	SHAPE	USE
Installation & operation manual	1		For the MS box installation and operation instructions
Adapter pipe (for liquid line)	1		Use for the connecting between the MS box and the TVR Multi-split Outdoor Unit. (The pipe diameter size is selected based on actual needs)
Adapter pipe (for low pressure line)	2		
Adapter pipe (for high pressure line)	2		

Optional Accessories

Table 2-3

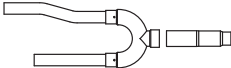
NAME	MODEL	SHAPE	USE
MS Branch Joint	TRIJ095HRU		Use for the indoor unit (capacity is 16-28 kW)

Locally purchased components

Table 2-4

NAME	USE
PVC drainage pipe	Use for drainage pipe for MS box; the length varies according to circumstances
Heat-insulated pipe	The inner diameter should be the same as the relative copper pipes and PVC pipes. The thickness should be (more than) 10mm, especially near wet areas.

2.3 Checklist

Exercise particular care concerning the following items during installation and check again after installation is complete:

Post-installation checklist

Check item	If defective	Check here.
Has the MS box been installed firmly?	The unit may fall, vibrate, or operate noisily.	
Did you carry out a gas leakage inspection?	The unit may fail to heat or cool as designed.	
Was the unit completely insulated? (Refrigerant pipes and drain pipes)	The unit may cause to leak of water.	
Does water flow slightly from the drain?	The unit may cause to leak of water.	
Is the supply voltage the same as the voltage indicated on the label?	The unit may fail to operate or burn up.	
Are there any wiring mistakes, erroneous wiring, or erroneous pipe connections?	The unit may fail to operate, burn up, or produce abnormal noise.	
Has the unit been grounded?	In the event of short-circuiting, the unit may pose a hazard.	
Is the thickness of the electrical wiring the same as described in the specifications?	The unit may fail to operate or burn up.	
Are all indoor and outdoor units properly installed?	The unit may fall, vibrate, or operate noisily.	
Are all electrical connections (both power and control) properly terminated?	The unit may fail to operate or burn up.	
Are the units properly grounded in accordance with current electrical codes?	The unit may fail to operate or burn up.	

Delivery checklist

Check item	Check here.
Has a cover been installed on the control box?	
Did you give the customer the installation manual?	

3 INSTALLATION SITE

Install the MS box at a location where the refrigerant noise cannot disturb the room occupants.

- To prevent the refrigerant noise from disturbing the people in the room, keep at least 5 m of piping between the occupied room and the MS box. See Figure A (page 2).
- If there is no false ceiling in the room, please add sound insulation around the piping between the MS box and the indoor unit, or keep greater length between the MS box and the occupied room. See Figure A (page 2).

Consider the following requirements when choosing the installation location and obtain the customer's consent:

- The location must be able to withstand the weight of the MS box.
- The location must allow reliable drainage.
- The location must allow inspection holes to be installed on the control box side. (A separate opening is necessary when lowering the product.)
- There must be adequate space in which to perform installation and service work.
- The length of pipe from the indoor unit to the outdoor unit must be less than or equal to the permissible pipe length (as listed in the installation manual that came with the outdoor unit).
- The installation location should not be sensitive to the noise of the refrigerant flowing through the pipes. Never install the pipes above the ceiling of an occupied room.
- The field pipes used to connect the outdoor unit and indoor unit need to be firmly secured. No vibration is permitted. Never install the pipes above the ceiling of an occupied room.

3.1 The multi MS box

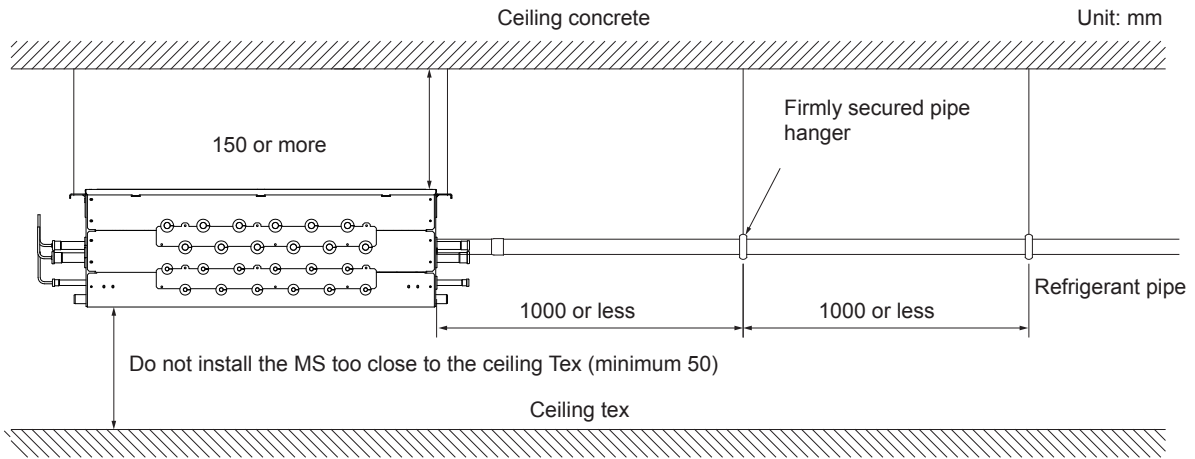

Fig.2-1

Unit: mm

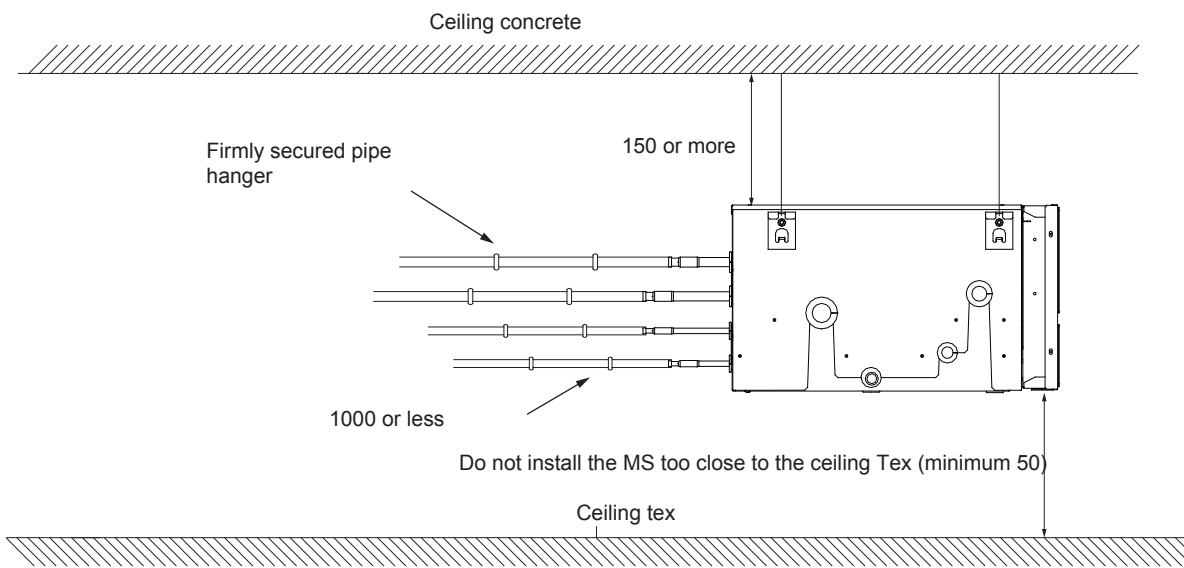

Fig.2-2

Unit: mm

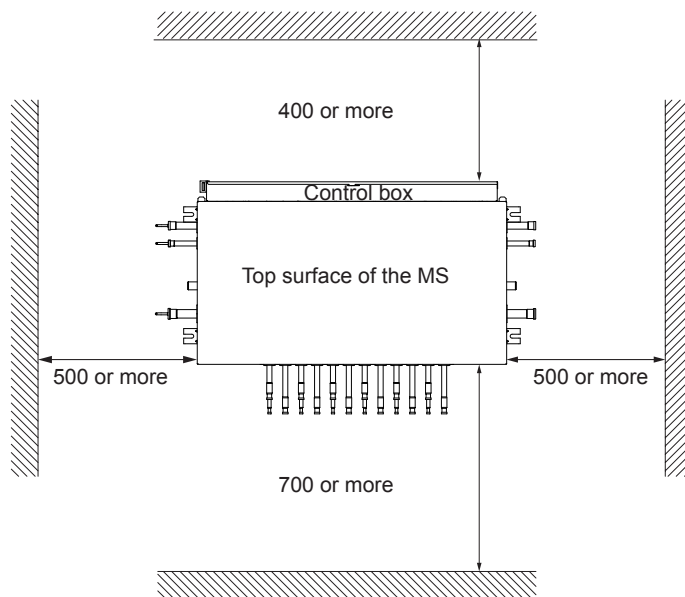

Fig.2-3

3.2 The single MS box

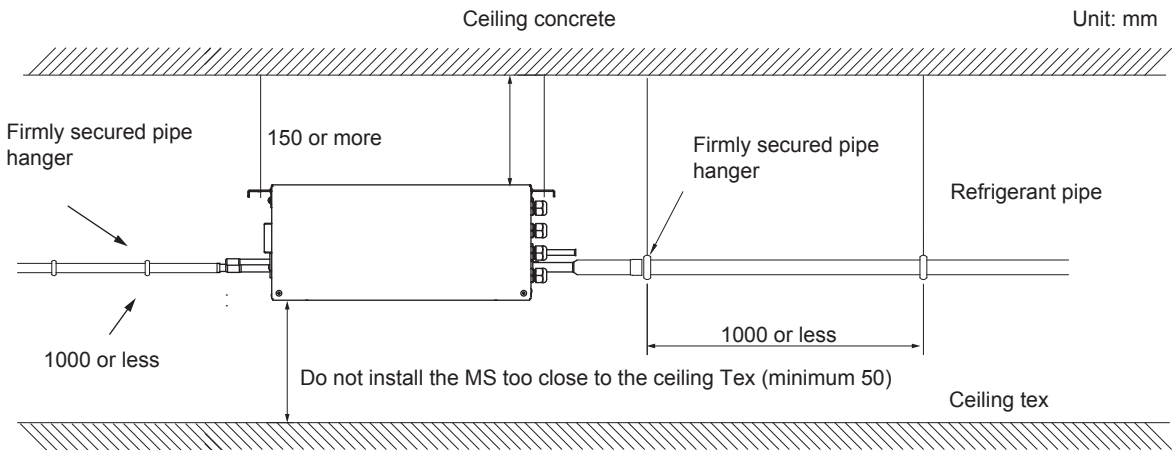

Fig.2-4

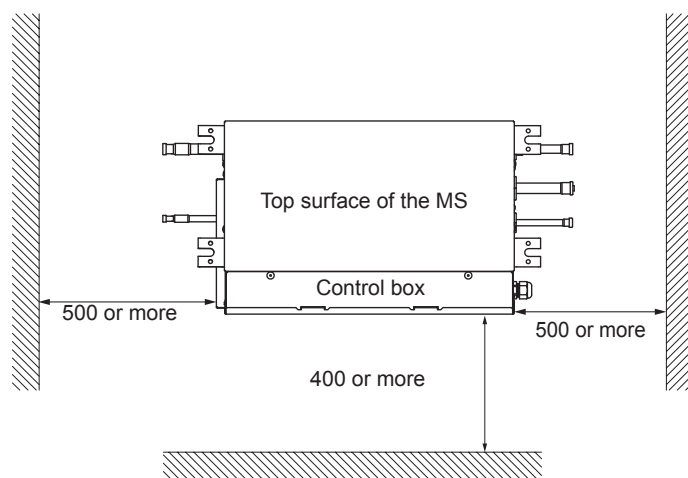

Fig.2-5

Note:1. The space of the single MS box shown in the diagram above is both required for ceiling-suspended installation and wall-mounted installation.

⚠ WARNING

- Securely install the unit at a location that is capable of withstanding its weight.
- Inadequate strength may cause the MS box to fall, resulting in bodily injury.

⚠ CAUTION

- Leave enough space to perform maintenance on the drain pan and control box.
- To prevent video and audio interference, install the MS box as well as the associated power wiring and signal transmission lines at least 1 m away from TVs and radios.
- However, depending on the reception, interference may result even if a minimum distance of 1 m is maintained.

4 PREPARATIONS BEFORE INSTALLATION

Install suspension bolts and hanging brackets as illustrated in the diagram below.

- Use a suspension bolt size of M10.
- Use mold-in inserts and embedded foundation bolts for new installations or hole-in anchor bolts or similar hardware for existing installations, taking care to install them in a manner that can withstand the unit's weight.

Suspension bolt spacing

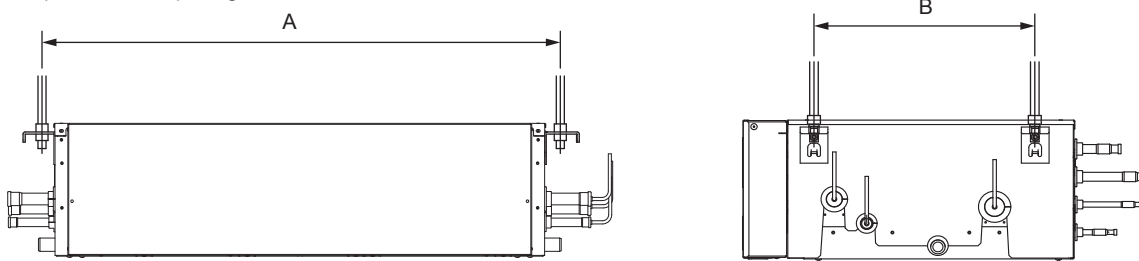

Mode selection box	A	B
MS01	483	172
MS04	702	383
MS06		
MS08		
MS10	1008	
MS12		

- Use the hanging brackets to support the connection pipes on both the front and back of the unit within 1 m of the unit's side.
- Placing an excessive amount of weight on the MS box's hanging brackets may cause the unit to fall, resulting in bodily injury.

Example installation

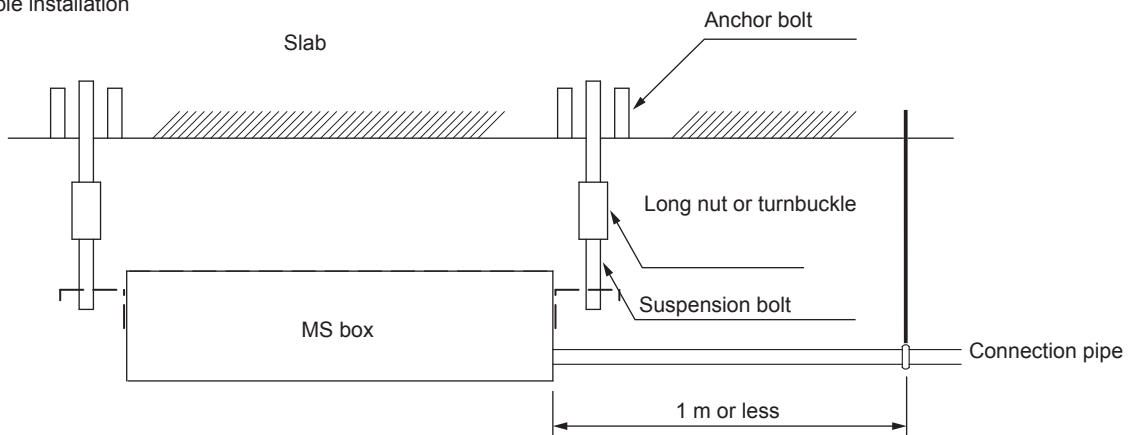

All the above parts must be supplied in the field

5 MS BOX INSTALLATION

⚠ WARNING

- Install at a location which is strong enough to withstand the set's weight.
- If the location is not strong enough or installation is not completed properly, the unit could fall and cause injury.
- Carry out special installation work to prevent strong wind or earthquakes.
- If installing by halves, the set will drop and cause an accident.

5.1 Install the main body

5.1.1 Install the suspension screw

1. Use a suspension bolt size of M10.
2. Remove the ceiling: For details about different architectural structures, please contact indoor decoration personnel.
 - a. To ensure that the ceiling is level and to avoid ceiling vibration, strengthen the ceiling plate's base frame.
 - b. Do not cut off the ceiling plate base frame.
 - c. Strengthen the base frame on the both sides of the fixed ceiling.
 - d. After hoisting and installing the main body, piping and wiring work should be completed in the ceiling. Decide the outlet directions of the pipes after selecting the installation location. Especially for positions which already have a ceiling, please install a pipe, drainage pipe, indoor and outdoor unit connecting wires and wire controlling wire to the connecting positions before hoisting the unit.

5.1.2 Hoisting install the MS box

1. Please use the pulley to hoist and install the MS box on the suspension bolt.
2. Please use the gradienter to adjust the MS box into a level position, or water leakage may occur.

5.2 The installation of suspension screw bolts

For installation scenarios of hanging screw bolts, refer to the following (Fig.5-1 and Fig.5-2)

Wooden struct

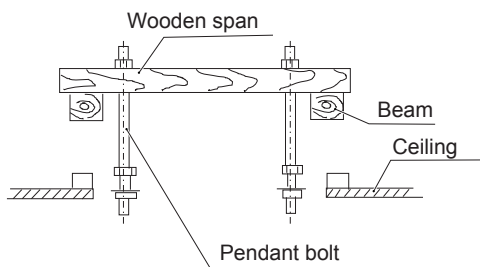

Put rectangular sticks across the beams, and set pendant bolts.

Old concrete roughcast

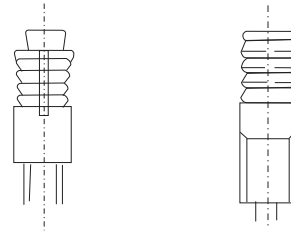

Use embedded bolts and embedded pulling plugs.

Fig.5-1

Steel beam and girder structure

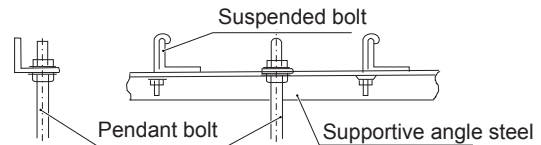

Secure and use supportive angle steel.

New concrete roughcast

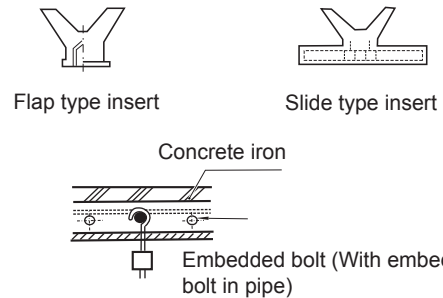

Fig.5-2

⚠ CAUTION

- The bolt material is constructed of high quality carbon steel (galvanized or covered other rust preventive materials on the surface) or stainless steel.
- Ceiling rust prevention measures are based on actual construction. For a detailed description please consult a building engineer.
- Suspending bolts must be secured. The method varies depending on the installation scenario.

5.3 Dimension diagrams

5.3.1 Dimensions of the multi MS box

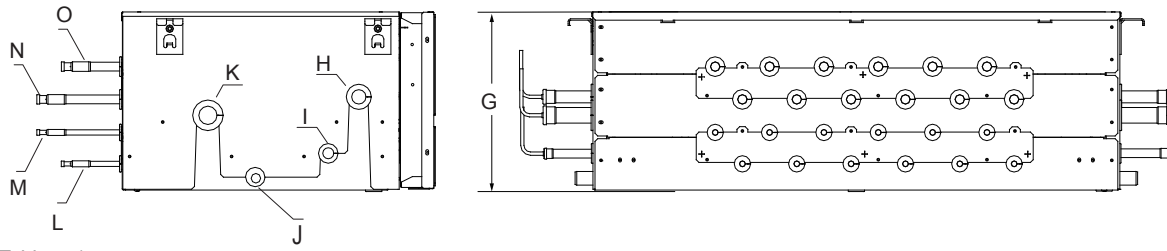

Table 5-1 Unit: mm

Model	A	B	C	D	E
MS04	889	702	668	700	574
MS06	889	702	668	700	574
MS08	1195	1008	974	700	574
MS10	1195	1008	974	700	574
MS12	1195	1008	974	700	574

Table 5-2 Unit: mm

Model	The multi MS box				
	F	G	H	I	J
	383	250	Φ22.2	Φ15.9	Φ25

Table 5-3 Unit: mm

Model	The multi MS box				
	K	L	M	N	O
	Φ28.6	Φ9.52	Φ6.35	Φ12.7	Φ15.9

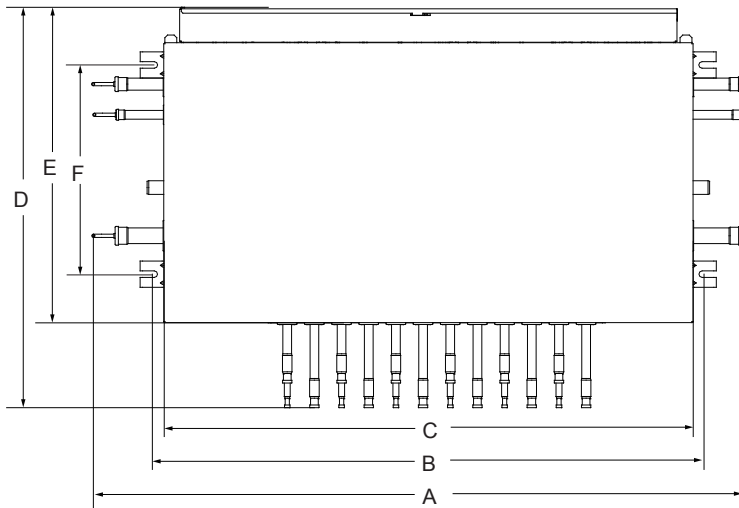

Fig.5-3

5.3.2 Dimensions of the single MS box (ceiling-suspended type)

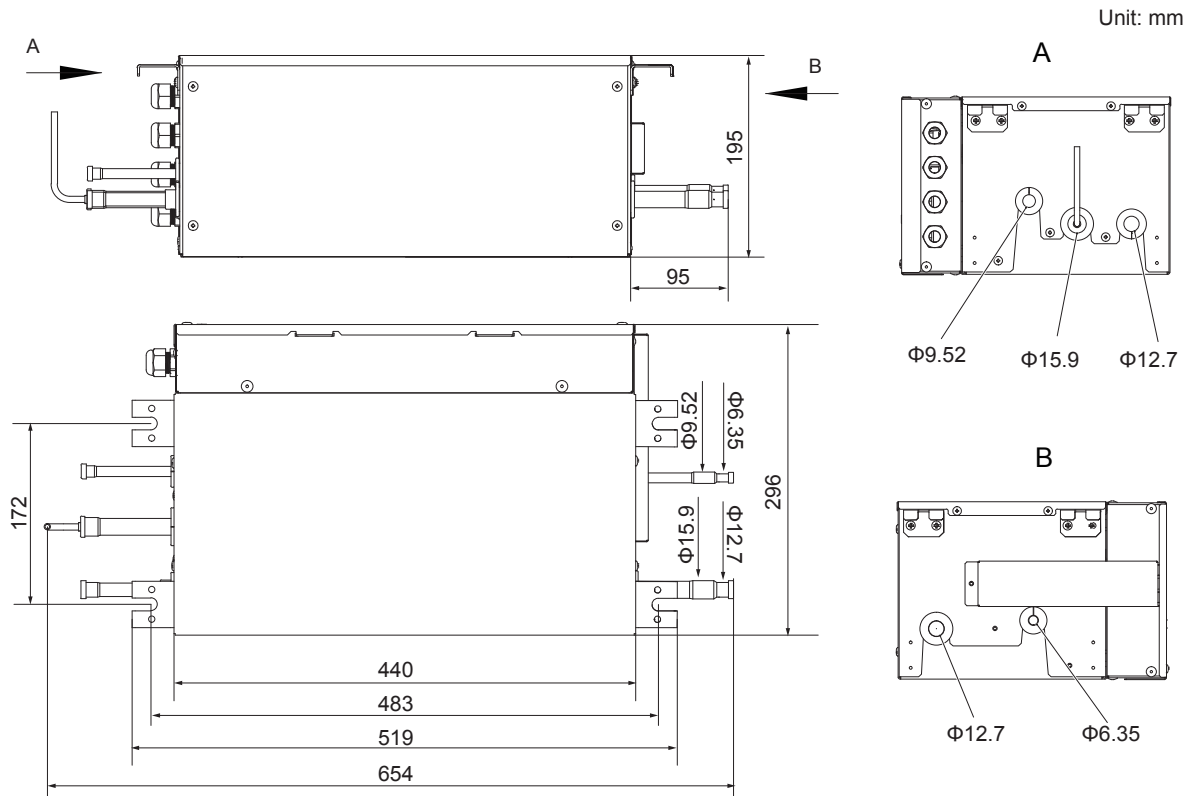

Fig.5-4

5.3.3 Dimensions of the single MS box (wall-mounted type)

Unit: mm

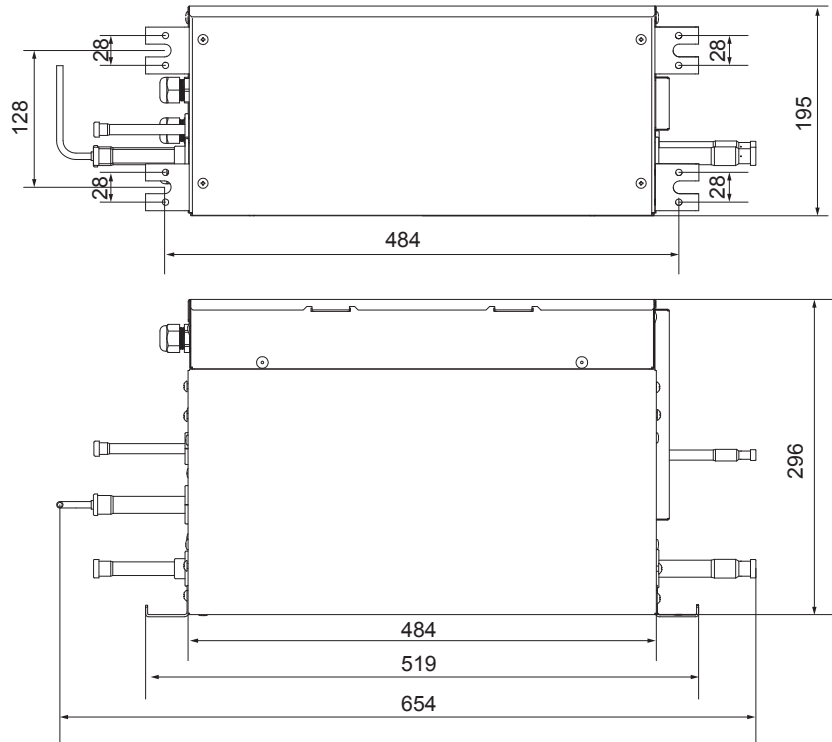

Fig.5-5

5.4 Hanging the MS box

1. Adjust the nut's site, the interval between the gasket (Down Side) and the ceiling should be adjusted according to actual construction circumstances. See Fig.5-6.
2. Hang the nut of the hanging screw bolt into the slotted hole of the installing ear.
3. Use the level gauge to confirm the horizontality of the unit. (Prevent slanting towards the non-drainage side; slanting slightly towards the drainage side is preferable) See Fig.5-7.

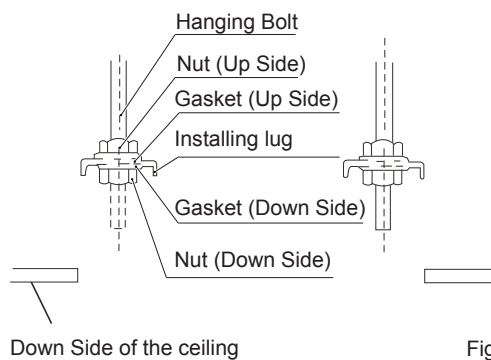

Fig.5-6

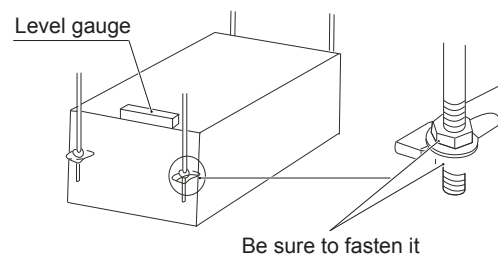

Fig.5-7

5.5 Multiple Installations of the single MS box

5.5.1 Replacing the electric control box

1. This unit has two different installation types:

(1) ceiling-suspended type and (2) wall-mounted type.

Choose the proper installation pattern based on the installation location.

2. The installation location for the electrical control box can be changed. (Fig.5-8)

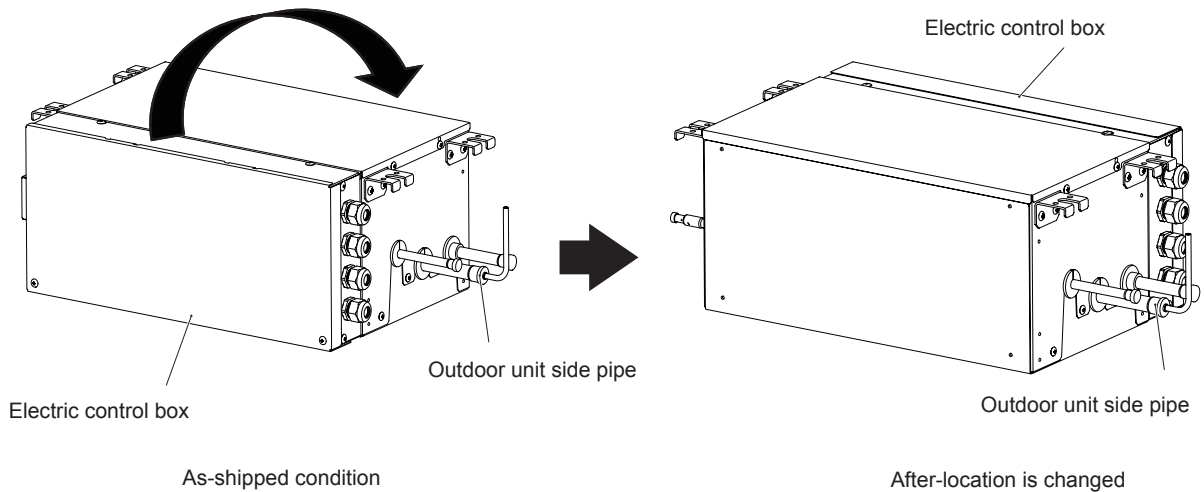
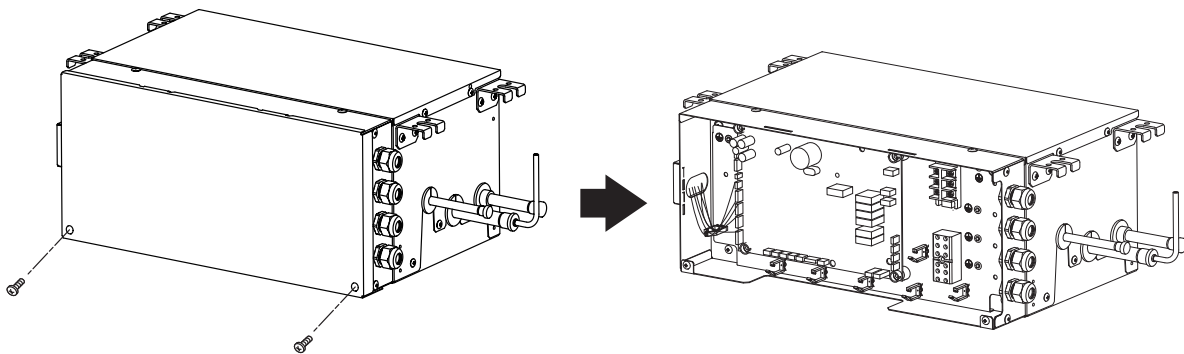

Fig.5-8

3. If the installation location of the electric control box must be changed because of the installation conditions, follow these steps:

(1) Remove the screws and pull off the electrical box cover.



(2) Remove 1 screw shown in the figure on the below. Remove the sealing plate.

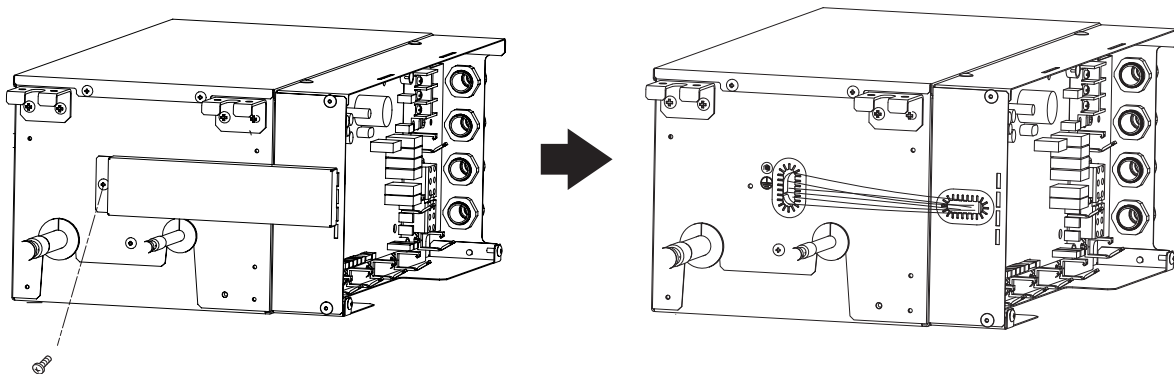

(3) Remove 4 screws shown in the figure on the below, remove the electrical box.

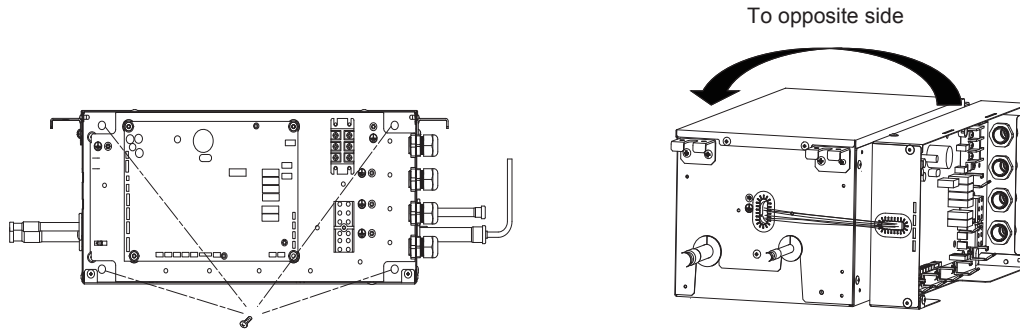

(4) Attach the electrical box and electrical box cover to the other side and secure them with the screws. Attach the sealing plate with 1 screw.

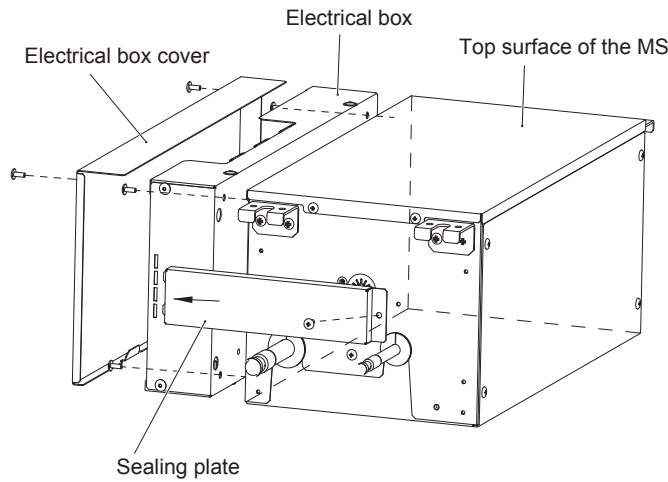

5.5.2 Wall-mounted type

1. Remove the 8 screws shown in the figure and pull off 4 hooks.

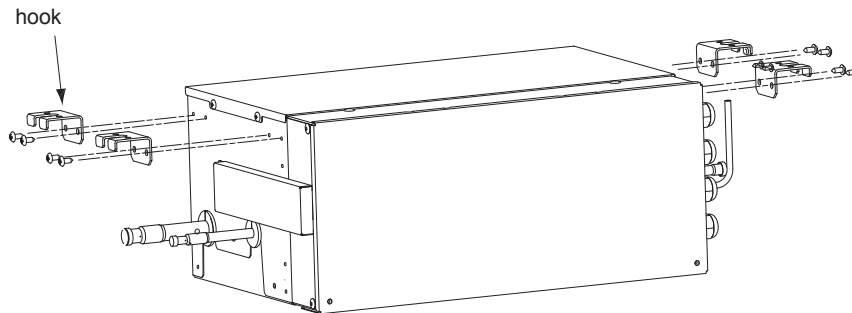

2. Attach the hooks shown in the figure with 8 screws from the previous step.

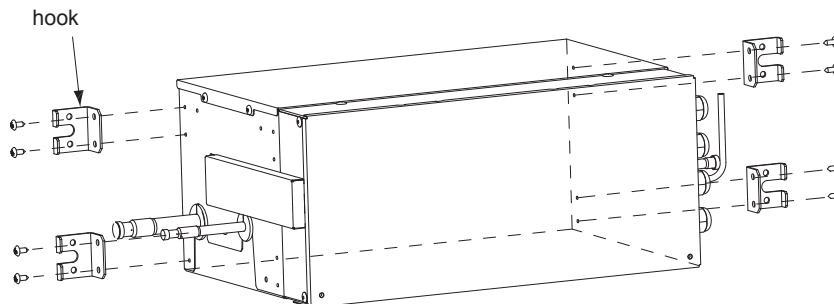

3. Create a gap between the wall, screw in the temporary screws (M5, field supply), and hang the MS box.

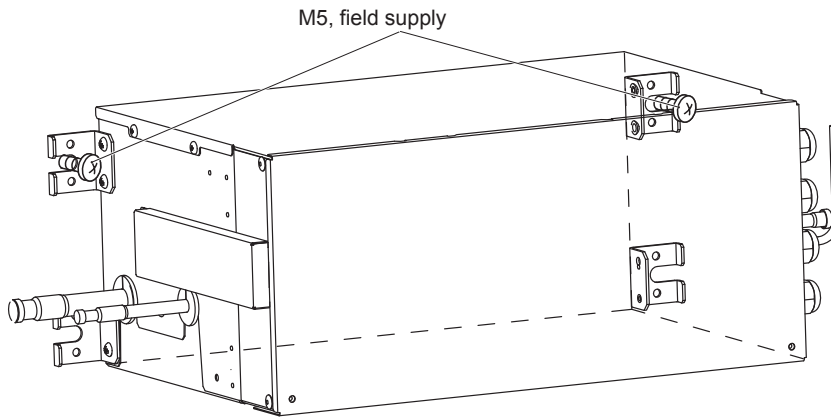

4. After checking with a level that the MS box is horizontal, fix the unit with 8 screws (M5, field supply).

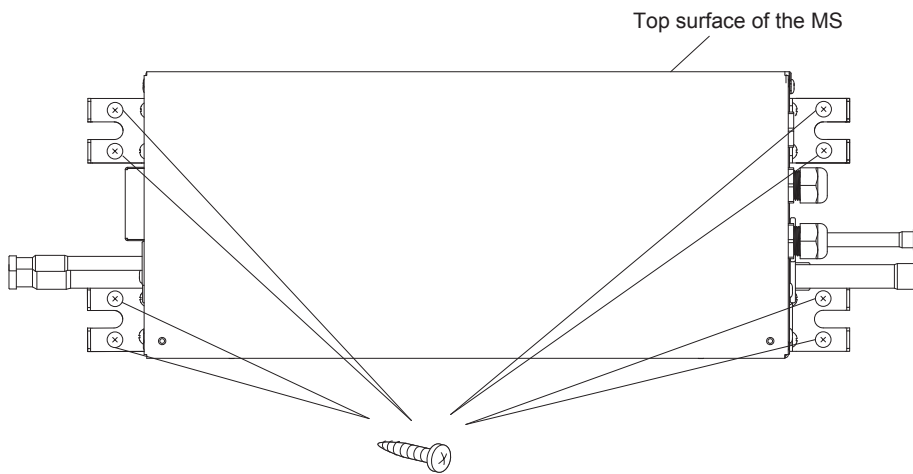

⚠ CAUTION

- The tilt of the unit should be within $\pm 5^\circ$ in the front/back and on the left/right.
- Be sure to install the unit with the top surface facing up.
- Do not install near bedrooms. The sound of refrigerant flowing through the piping may sometimes be audible.

6 REFRIGERANT PIPING

For instructions for installing piping between the outdoor unit and the MS box, selecting a refrigerant branch kit, and installing piping between the refrigerant branch kit and indoor units, refer to the installation manual included with the outdoor unit.

Before beginning the installation work, be sure to verify that the type of refrigerant used is R410A. (The unit will not operate correctly with a different type of refrigerant.)

Insulate all of the piping, including the liquid pipes, HP/LP gas pipes, suction gas pipes, gas pipes, and each of the pipe connections. Not insulating these pipes could result in water leaks or burns.





In particular, low-temperature gas flows in the HP/LP gas piping during full cooling operation, so the same amount of insulation as used for the suction gas pipes is required.

In addition, high-temperature gas flows in the HP/LP gas piping and the gas piping, so use insulation that can withstand more than 120°C.

Select insulation material which is suited to the installation environment. For details, refer to the Engineering date book. Failure to do so could cause condensation to form on the surface of the insulation.

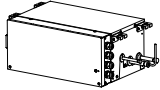
6.1 Range of MS box application

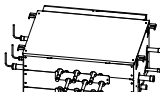
Table.6-1

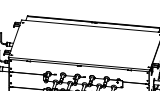
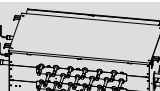
MS outside drawing	Model	Max. connecting indoor unit quantity	Max. total indoor unit capacity (Unit:kw)
	MS01	8	32
	MS04	20	49
	MS06	30	63
	MS08	40	85
	MS10	47	85
	MS12	47	85

6.2 Connecting diagram of the multi MS box and indoor unit

Connecting diagram 1

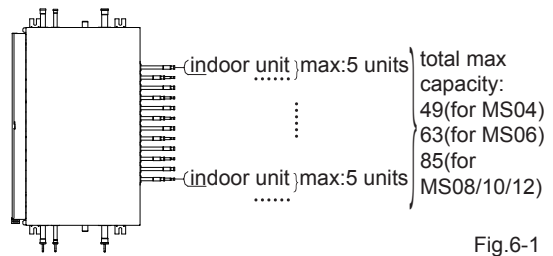

Fig.6-1

Suitable model	MS04	MS06	MS08	MS10	MS12
----------------	------	------	------	------	------

Note:

- 1.Capacity matching with each indoor unit group is lower than 16KW
2. If the indoor units do not have auto mode function, then each group of MS can be connected with five indoor units at most for one time; other wise, it can be connected with only one indoor unit at most.
3. Indoor units in the same group of MS can not be operated in cooling or heating mode at the same time, or operated in heating and air supplying mode at the same time, otherwise it will be mode conflict.

Connecting diagram 2

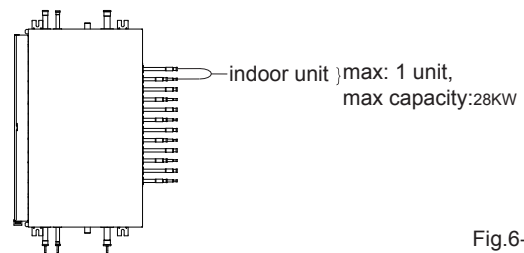
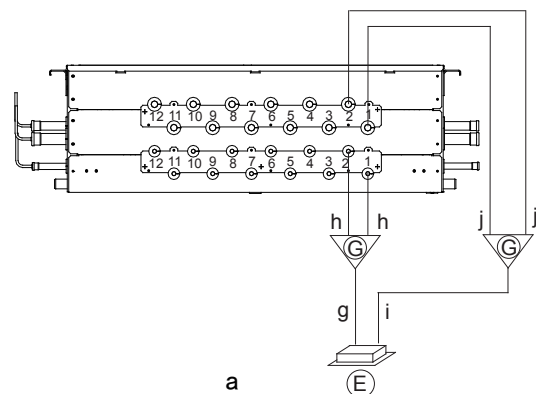

Fig.6-2

Suitable model	MS04	MS06	MS08	MS10	MS12
----------------	------	------	------	------	------

Note:

Before connecting the models of indoor units between 16KW and 28KW, use an optional branch pipe (Model:TRIJ095HRU) and merge the two ports as follow : 【No.1&No.2】 , 【No.3& No.4】 , 【No.5&No.6】 , 【No.7&No.8】 , 【No.9&No.10】 , 【No.11&No.12】 .(refer to Fig.6-3a,the Fig.6- 3b is a wrong way.



a

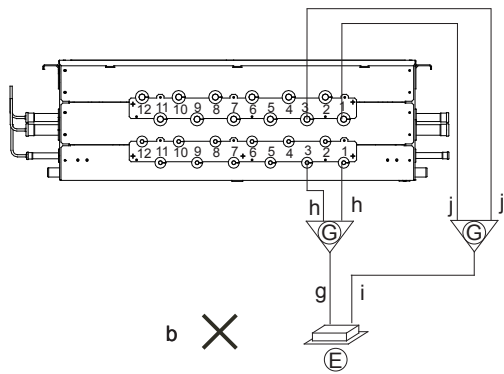

Fig.6-3

6.3 Connecting diagram of the single MS box and indoor unit

Connecting diagram 1

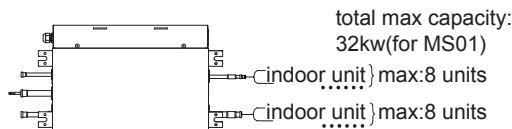

Fig.6-4

Suitable model:MS01

Note:

- 1.Capacity matching with each indoor unit group is lower than 32KW
2. If the indoor units do not have auto mode function, then each group of MS can be connected with eight indoor units at most for one time; other wise, it can be connected with only one indoor unit at most.
3. Indoor units in the same group of MS box can not be operated in cooling or heating mode at the same time, or operated in heating and air supplying mode at the same time,otherwise it will be mode conflict.

6.4 Requests for the length of pipes connecting indoor and outdoor units with the MS box and altitude difference

1. Allowable pipe length please refers to the outdoor unit instruction.
2. Allowable pipe altitude difference please refers to the outdoor unit instruction.

CAUTION

- Do not let air, dust, or other impurities fall in the pipe system during the time of installation.
- The connecting pipe should not be installed until the indoor and outdoor units have been fixed already.
- Keep the connecting pipe dry, and do not let moisture in during installation.
- The connecting copper pipes should be wrapped up by insulated materials (more than 10mm thick).

6.5 Pipe size selection

6.5.1 MS box pipe size

Table 6-1

Unit: mm

Model		The single MS box	The multi MS box
Connect the outdoor unit side	Liquid pipe	Φ9.52	Φ15.9
	High pressure gas pipe	Φ12.7	Φ22.2
	Low pressure gas pipe	Φ15.9	Φ28.6
Connect the indoor unit side	Liquid pipe	Φ9.52	Φ9.52
	gas pipe	Φ15.9	Φ15.9

Note:

Use to connect the indoor unit refrigerant system; a soft copper pipe (TP2M) is recommended. Length should be selected according to actual needs.

6.5.2 Indoor unit connecting pipe size

Table 6-1

Unit: mm

Lower side indoor unit capacity A (Unit: kW)	Branch pipe side	
	Gas pipe	Liquid side
A < 5.6	Φ12.7	Φ6.35
5.6 ≤ A ≤ 16	Φ15.9	Φ9.52

6.6 The procedure of connecting pipes

1. Measure the required length of the connective pipe, and follow these procedures to make the connective pipes. (Refer to Pipeline Connection for details)

1) First connect the indoor unit, and then connect the outdoor unit.

a.The pipe bend should be handled carefully, without damaging the pipe and insulation layer.

b. When connecting or disconnecting the pipeline, be sure to use two spanners concurrently.

c. Do not rest the weight of the connecting pipe on the adapter of the indoor unit. An excessively heavy load on the adapter of the indoor unit may deform the pipe and thus affect the cooling/heating effects.

2) The valve of the outdoor unit should be closed completely (default factory setting). Every time you connect the pipe, unscrew the nut at the valve, and connect the flared pipe (within 5 minutes). If the nut is put away for a long time after being unscrewed from the valve, dust and other foreign substance may enter the pipeline system and cause faults.

3) After the refrigerant pipe is connected to the indoor and outdoor units, expel air as instructed in the "Expel air" section. After expelling the air, screw on the nut at the maintenance opening.

a. Precautions for the flexible part of the pipeline

i. The bend angle shall not exceed 90°. (See Fig.6-5)

Use a thumb to bend the pipe



Minimum radius 100mm

Fig.6-5

- ii. The bend shall preferably be in the middle of the pipe length, and a higher bend radius is preferred.
 - iii. Do not bend the flexible pipe more than 3 times.
- b. Bend the thin-wall connective pipe (See Fig.6-6)

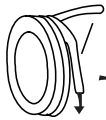

Method of unleashing the spooled pipe
Straighten the pipe end

Fig.6-6

- i. When bending the pipe, cut out a notch of the desired size at the bend of the adiabatic pipe, and then expose the pipe (wrap the pipe with the wrapping tape after bending it).
- ii. The radio of the elbow pipe should be as large as possible to prevent flattening or crushing.
- iii. Use the pipe bender to make a closed elbow pipe.

c. Use purchased copper pipe

When purchasing a copper pipe, be sure to use the heat insulation materials of the same type (with a thickness of over 9mm).

2. Deploy the pipelines

1) Drill a porthole on the wall, and put the hole sheath and hole cover through the wall.

2) Place the connective pipe together with the indoor & outdoor connection wires. Use wrapping tape to bind them tightly. Do not let air penetrate it, or this could lead to condensation and drops of moisture.

3) Pull the connective wrapped connective pipe from outside through the sheath, which passes through the wall, and lead it into the room.

3. Make a vacuum of connective pipeline.

4. After completing the above steps, the spool of the valve of the outdoor unit should be completely open, and the refrigerant pipeline of the indoor unit and the outdoor unit should be smooth.

5. Use a leakage detector or soapy water to check carefully for leakage and prevent leakage.

6. Attach an adiabatic envelope (accessory) at connective pipe adapter of the indoor unit, and wrap it tightly with the wrapping tape to prevent condensation and leakage.

6.7 Pipeline connection

6.7.1 connecting diagram of the MS box and Indoor unit

6.7.1.1 Gas pipes connect with the indoor unit

Table 6-3

Unit: mm

connecting diagram	P.S
	(A) MS box
	(B) Pipe Φ12.7 (capacity lower than 5.6kW)
	(C) Pipe Φ15.9 (capacity larger than 5.6kW)
	(D) Cut here
	(E) Remove brazed cap
	Caution: Remove the brazed cap or cut the pipe, to connect with the indoor unit.

6.7.1.2 Liquid pipes connect with the indoor unit

Table 6-4

Unit: mm

connecting diagram	P.S
	(A) MS box
	(B) Pipe Φ6.35 (capacity lower than 5.6kW)
	(C) Pipe Φ9.52 (capacity larger than 5.6kW)
	(D) Cut here
	(E) Remove brazed cap
	Caution: Remove the brazed cap or cut the pipe, to connect with the indoor unit.

6.7.2 connecting diagram of the multi MS box and outdoor unit

6.7.2.1 Suction gas pipes connect with the outdoor unit

Table 6-5 Unit: mm

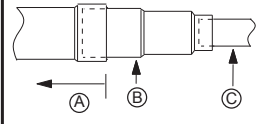
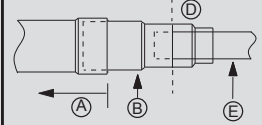
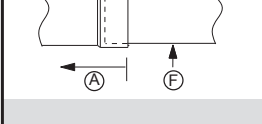
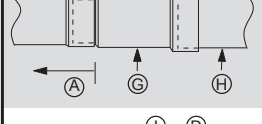
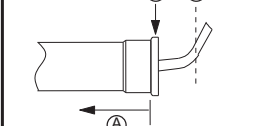
connecting diagram	P.S
	(A) MS box (B) Pipe accessory from the MS box (C) Pipe $\Phi 19.1$ (capacity < 22.4kW)
	(D) Cut here (E) Pipe $\Phi 22.2$ (22.4kW \leq capacity < 33kW)
	(F) Pipe $\Phi 28.6$ (33kW \leq capacity < 71kW) (G) Pipe accessory from the MS box
	(H) Pipe $\Phi 34.9$ (71kW \leq capacity < 85kW) (I) Remove brazed cap
	Caution: Cut the tip of the MS box piping (both of the gas and liquid pipe), remove the gas, and then remove the brazed cap.

6.7.2.2 HP gas pipes connect with the outdoor unit

Table 6-6 Unit: mm

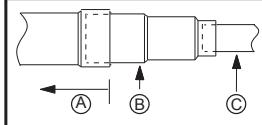
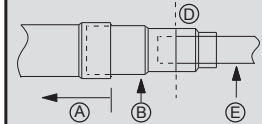
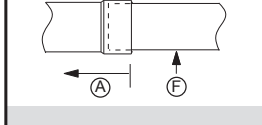
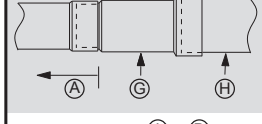
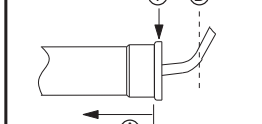
connecting diagram	P.S
	(A) MS box (B) Pipe accessory from the MS box (C) Pipe $\Phi 15.9$ (capacity < 22.4kW)
	(D) Cut here (E) Pipe $\Phi 19.1$ (22.4kW \leq capacity < 33kW)
	(F) Pipe $\Phi 22.2$ (33kW \leq capacity < 71kW) (G) Pipe accessory from the MS box
	(H) Pipe $\Phi 28.6$ (71kW \leq capacity < 85kW) (I) Remove brazed cap
	Caution: Cut the tip of the MS box piping (both of the gas and liquid pipe), remove the gas, and then remove the brazed cap.

6.7.2.3 Liquid pipes connect with the outdoor unit

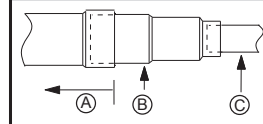
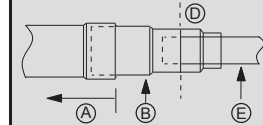
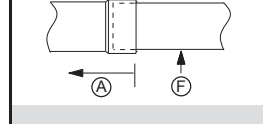
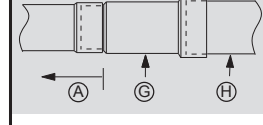
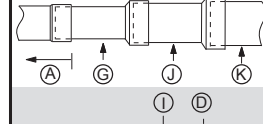
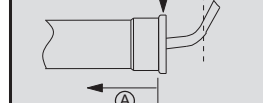
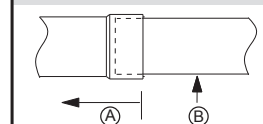
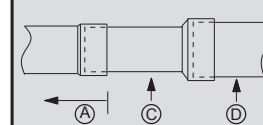
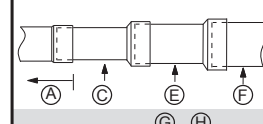
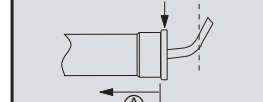

Table 6-7 Unit: mm

connecting diagram	P.S
	(A) MS box (B) Pipe accessory from the MS box (C) Pipe $\Phi 9.52$ (capacity < 33kW)
	(D) Cut here (E) Pipe $\Phi 12.7$ (33kW \leq capacity < 47kW)
	(F) Pipe $\Phi 15.9$ (47kW \leq capacity < 71kW) (G) Pipe accessory from the MS box
	(H) Pipe $\Phi 19.1$ (71kW \leq capacity < 85kW) (J) Pipe accessory from the MS box
	(K) Pipe $\Phi 22.2$ (71kW \leq capacity < 85kW) (I) Remove brazed cap
	Caution: Cut the tip of the MS box piping (both of the gas and liquid pipe), remove the gas, and then remove the brazed cap.

6.7.3 connecting diagram of the single MS box and outdoor unit

6.7.3.1 Suction gas pipes connect with the outdoor unit

Table 6-8 Unit: mm

connecting diagram	P.S
	(A) MS box (B) Pipe $\Phi 15.9$ (capacity < 16.8kW)
	(C) Pipe accessory from the MS box (D) Pipe $\Phi 19.1$ (16.8kW \leq capacity < 22.4kW)
	(E) Pipe accessory from the MS box (F) Pipe $\Phi 22.2$ (22.4kW \leq capacity < 32kW)
	(G) Remove brazed cap (H) Cut here
	Caution: Cut the tip of the MS box piping and then remove the brazed cap.

6.7.3.2 HP gas pipes connect with the outdoor unit

Table 6-9

Unit: mm

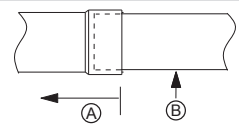
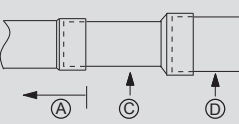
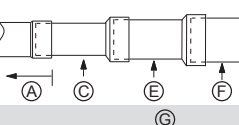
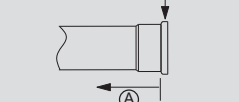
connecting diagram	P.S
	(A) MS box
	(B) Pipe $\Phi 12.7$ (capacity < 16.8kW)
	(C) Pipe accessory from the MS box
	(D) Pipe $\Phi 15.9$ (16.8kW \leq capacity < 22.4kW)
	(E) Pipe accessory from the MS box
	(F) Pipe $\Phi 19.1$ (22.4kW \leq capacity < 32kW)
	(G) Remove brazed cap
	Caution: Remove the brazed cap. For connecting with the outdoor unit.

6.7.3.3 Liquid pipes connect with outdoor unit

Table 6-10

Unit: mm

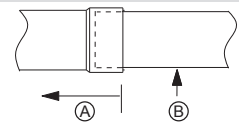
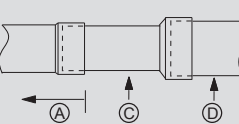
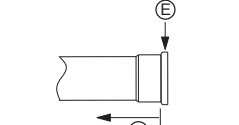
connecting diagram	P.S
	(A) MS box
	(B) Pipe $\Phi 9.52$ (capacity < 32kW)
	(C) Pipe accessory from the MS box
	(D) Pipe $\Phi 12.7$
	(E) Remove brazed cap
	Caution: Remove the brazed cap. For connecting with the outdoor unit.

CAUTION

- Please be careful when installing connective piping, do not let any air, dust, or other foreign substances enter the system.
- Connection of pipes can be conducted after the indoor and outdoor units are secured.
- The connective pipe must be kept dry during installation. Do not let water enter it.
- Connective copper pipe must be wrapped insulation layer (at least 9 mm thickness)

6.8 Welding the copper pipe

Use braze-welding for the low pressure gas pipe, high pressure gas pipe, and liquid pipe which are connected to the MS and the outdoor unit.

If there are any unused MS ports which are not hermetically sealed, intact welding will be necessary.

⚠ CAUTION

- During welding, use a wet cloth to pack the copper pipe which is near the MS.
- During welding, use nitrogen gas to protect the welding.

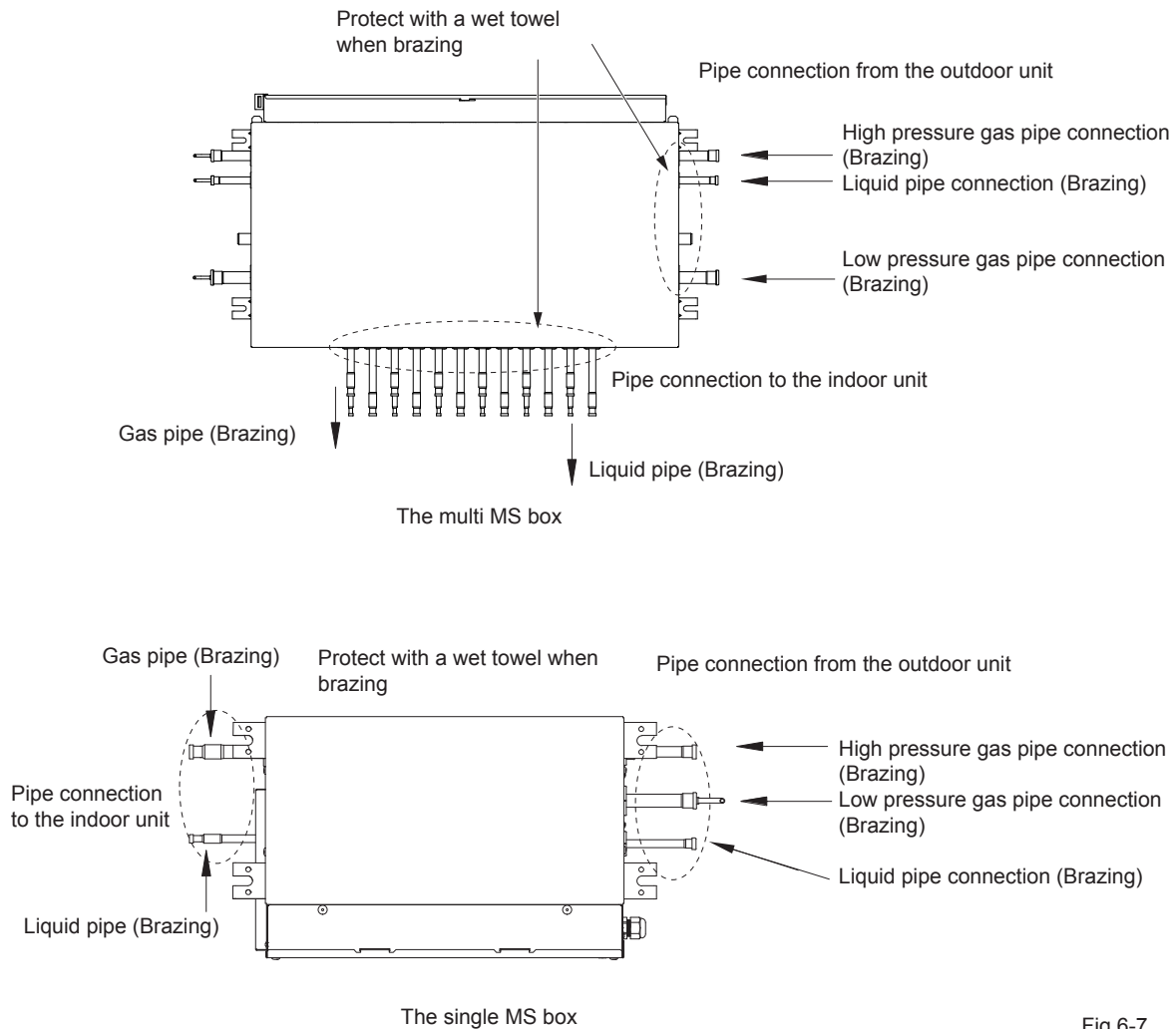

Fig.6-7

6.9 Checking for leakage

Check all the joints with the leakage detector or soapy water.

6.10 Airtight test

After installation and before connecting to the outdoor unit, the refrigerant pipe must undergo an airtight test with 3.92 MPa (40kgf/cm²) nitrogen for 24 hours from the low pressure gas pipe, high pressure gas pipe, and liquid pipe.

6.11 Air purging

Connect the refrigerant pipe with the low pressure gas pipe, high pressure gas pipe, and liquid pipe of the outdoor unit. Use a vacuum pump to vacuum from the low pressure gas pipe, high pressure gas pipe, and liquid pipe of the outdoor unit. The following detailed procedure is in accordance with the instructions in the installation manual that came with the outdoor unit to perform vacuum drying.

6.12 Open/Close the valves

Open/Close the spools or the valves of the outdoor unit with an inner hexagon spanner.

CAUTION

Don't use the refrigerant of the outdoor unit to create the vacuum.

6.13 Thermal insulation

To process the thermal insulation for gas side and liquid side piping, Please completely insulate the gas side and liquid side piping, due to the fact that the ambient temperature is very low during cooling mode.

1. Thermal insulation of at least 120 °C material shall be applied to the gas side piping.
2. Apply attached thermal insulation material to tightly wrap the connective part of indoor piping, leaving no gaps.
3. To prevent condensation, do not leave any gaps between the insulation material and the unit body (See Fig.6-8).
4. Insulation tube installation instructions for unused branch ports (indoor unit side) (gas and liquid pipes) (See Fig.6-9) .

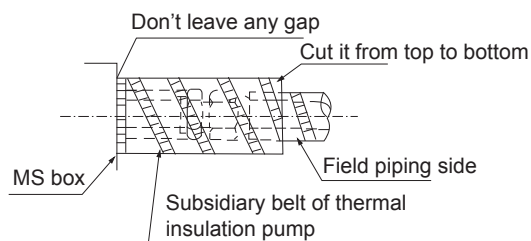

Fig.6-8

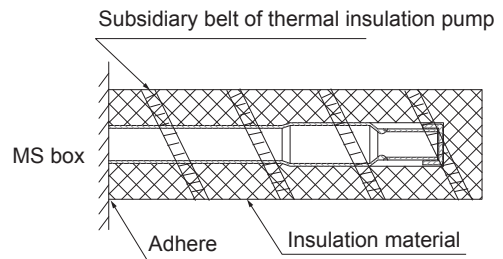

Fig.6-9

CAUTION

- Insulate all of the piping including the liquid pipes, HP/LP gas pipes, suction gas pipes, gas pipes, and each of the pipe connections.
- Not insulating these pipes could result in water leakage or burning. In particular, low-temperature gas flows in the HP/LP gas pipes during full cooling operation, so the same amount of insulation as used for the suction gas pipes is required. In addition, high-temperature gas flows in the HP/LP gas piping and the gas piping, so use insulation that can withstand more than 120°C.
- When reinforcing the insulation material in accordance with the installation environment, also make sure to reinforce the insulation on the piping that protrudes from the unit.
- Insulation material required for reinforcement work should be supplied in the field.
- For more information, refer to the Engineering data book

CAUTION

Wrap insulation material with the seam facing up. (Refer to Fig.6-10)

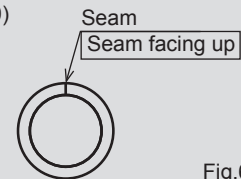

Fig.6-10

7 ARRANGEMENTS FOR DRAINAGE PIPE

7.1 The multi MS box drain pipes installation

1. Please use a flexible drainage pipe to connect the MS drainage port and the PVC pipes, and use the snap ring for fastening.
2. While connecting other drain pipes please use a hard PVC binder and check for leaks. or not.
3. The waterspout joints and drain pipes (especially the indoor parts) of the main unit must be evenly wrapped with insulated casing pipes, and the lacing belt should be tightened, in order to prevent air admission and condensation.
4. To prevent condensation from flowing back inside the air-conditioner, the drainage pipes should incline towards the outdoor side (the drainage side), the gradient should be over 1/100, and defects such as prominence and water absorption should not be present. (See Fig.7-2a)
5. Do not use excessive force when connecting the drain pipes, to avoid damaging the main unit. The transverse pull-out of the drain pipes should be kept within 20m In addition, set a supporting point every 0.8-1.0m, for avoiding the bending of drain pipes (See Fig.7-2a); use hard polyethylene (PE) pipes to connect the drain pipes and the connecting pipes, and use the connecting pipes to fasten the drain pipes (See Fig.7-1).
6. To prevent condensation, do not leave any gaps between the drain pipes and the body of the MS box (See Fig.7-1).
7. Centrally install the drain pipes. Please follow Fig.7-2 to match the pipes.
8. The end of the drain pipe should be at least 50mm from the ground or the bottom of the drain tank, and should not be put into the water. If the condensate water pours directly into the waste water drain, the sparge pipe should be bent up to a U-shape water seal, in order to prevent the a foul smell from entering the room through the drain pipe.

CAUTION

To avoid water leakage, every joint of the drainage system must be sealed up.

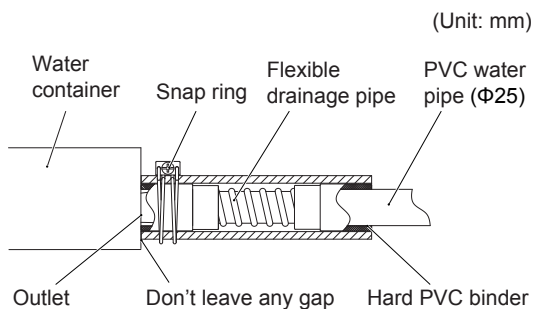
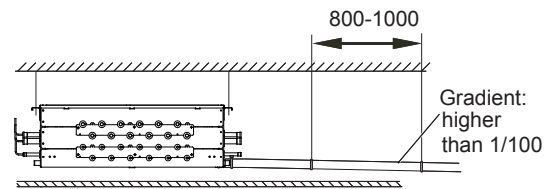
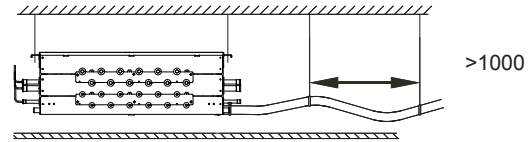

Fig.7-1



a ○



b ✕

Fig.7-2

As long as possible (about 100)

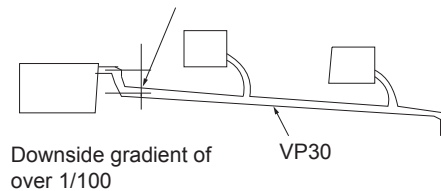

Fig.7-3

7.2 Drainage test

7.2.1 Before doing a drainage test, keep the drainage piping smooth, and check every joint to ensure whether it is sealed or not.

7.2.2 For newly built rooms, do the drainage test before plastering the ceiling.

1. Use a water main to fill the water tank with 500-1000ml water.
2. Check whether water drains normally and whether there is leakage on the connectors.

NOTE

There is no need to install the drainage pipe for the single MS box.

8 ELECTRIC WIRING

8.1 Wiring

⚠ CAUTION

1. Special power shall be applied within the rated voltage range. This air conditioner's external circuit must be grounded. This means that the power cable of the MS unit shall be jointed with a reliable external grounding wire.

2. Electric wiring must be completed by professionals, and wiring must be completed according to the wiring label.

3. The fixing circuit must be wired with an all-pole disconnection device at the 3mm switching distance of the contact.

4. Set the electrical leakage device according to national electric code.

5. The distance between the power cord and signalling line must be at least 300 mm to prevent electrical interference, malfunction or damage to electrical components. At the same time, these line must not come into contact with the piping and valves.

6. There are attached connective wires. If the length is insufficient, it must be replaced using a wire of appropriate length according the same specifications. Under normal circumstances, overlapping the two wires is not allowed but an exception is made when it is welded, fixed, and wrapped using an insulation adhesive band.

7. Connect to the power supply only after all the wiring and connection works have been completed, and carefully check that they are correct.

8.2 Wiring for the MS box power wire and signal wire

Please use a dedicated power supply that is different from the outdoor unit for the MS box power.

The power, electrical leakage protectors and operation switches for each indoor unit that are connected to the same outdoor unit and the MS box should be used by both.

The MS box power cables should be connected to the terminals with the label "L,N,⊕", and the MS box control wires should be connected to the position with the label "P, Q, E ⊕" and correspond to the "P, Q, E ⊕" wiring position for the outdoor and indoor units.

8.3 Power specification

The power supply specifications are as follows:

Table 8-1

Power	Phase	1-Phase
	Volt and frequency	220-240V~50/60Hz
UPS (For MS01)	Phase	1-Phase
	Volt and frequency	220-240V~50/60Hz

Note:UPS only use AC power, prohibit Using DC power.

1. A power circuit (Refer to Table 8-2) must be provided for connection of the unit. This circuit must be protected with the required safety devices, i.e. a main switch, a slow blow fuse on each phase and an earth leakage circuit breaker.
2. When using residual current operated circuit breakers, be sure to use a high-speed type (0.1 second or less) 30mA rated residual operating current.
3. Use copper conductors only.
4. Use insulated wire for the power cord.
5. Select the wire diameters(minimum value) individually for each unit based on the table 8-2 and table 8-3.
6. Select circuit breaker that having a contact separation in all poles not less than 3 mm providing full disconnection, where MFA is used to select the current circuit breakers and residual current operation breakers.

Table 8-2

Model	Hz	Voltage	Units		Power supply		Power (W)
			Voltage range		MCA	MFA	
			Min.	Max.			
MS01					0.30		57
MS04					0.38		69
MS06	50	220-240	198	264	0.63	15	115
MS08	/60				0.80		138
MS10					0.90		173
MS12					1.10		196

MCA: Min. Circuit Amps (A); MFA: Max. Fuse Amps (A)

Table 8-3

Rated current of appliance (A)	Nominal cross-sectional area (mm ²)	
	Flexible cords	Cable for fixed wiring
≤3	0.5 and 0.75	1 to 2.5
>3 and ≤6	0.75 and 1	1 to 2.5
>6 and ≤10	1 and 1.5	1 to 2.5
>10 and ≤16	1.5 and 2.5	1.5 to 4
>16 and ≤25	2.5 and 4	2.5 to 6
>25 and ≤32	4 and 6	4 to 10
>32 and ≤50	6 and 10	6 to 16
>50 and ≤60	10 and 16	10 to 25

8.4 Wiring requirements for control wire

1. Three-core shielded cable should be used for communication wiring. The cross-sectional area of each core of the communication wiring is not less than 0.75 mm², and the length must not exceed 1200m. A communication error may result when the communication wiring exceeds these limitations.
2. All the shielding wires in the network should be interconnected, and finally connected together to the metal plate grounding.
3. Do not tie up the control wire with the refrigerant pipes and power wires etc. When the power wire and control wire use a parallel layout, a distance of 300mm should be maintained between them, to prevent signal source interference.
4. The control wire can not be a closed loop.

NOTE

The above parameters are for reference purposes only. For further details, refer to the specific model capacity and the relative National Electric Code.

8.5 Example of communication wiring

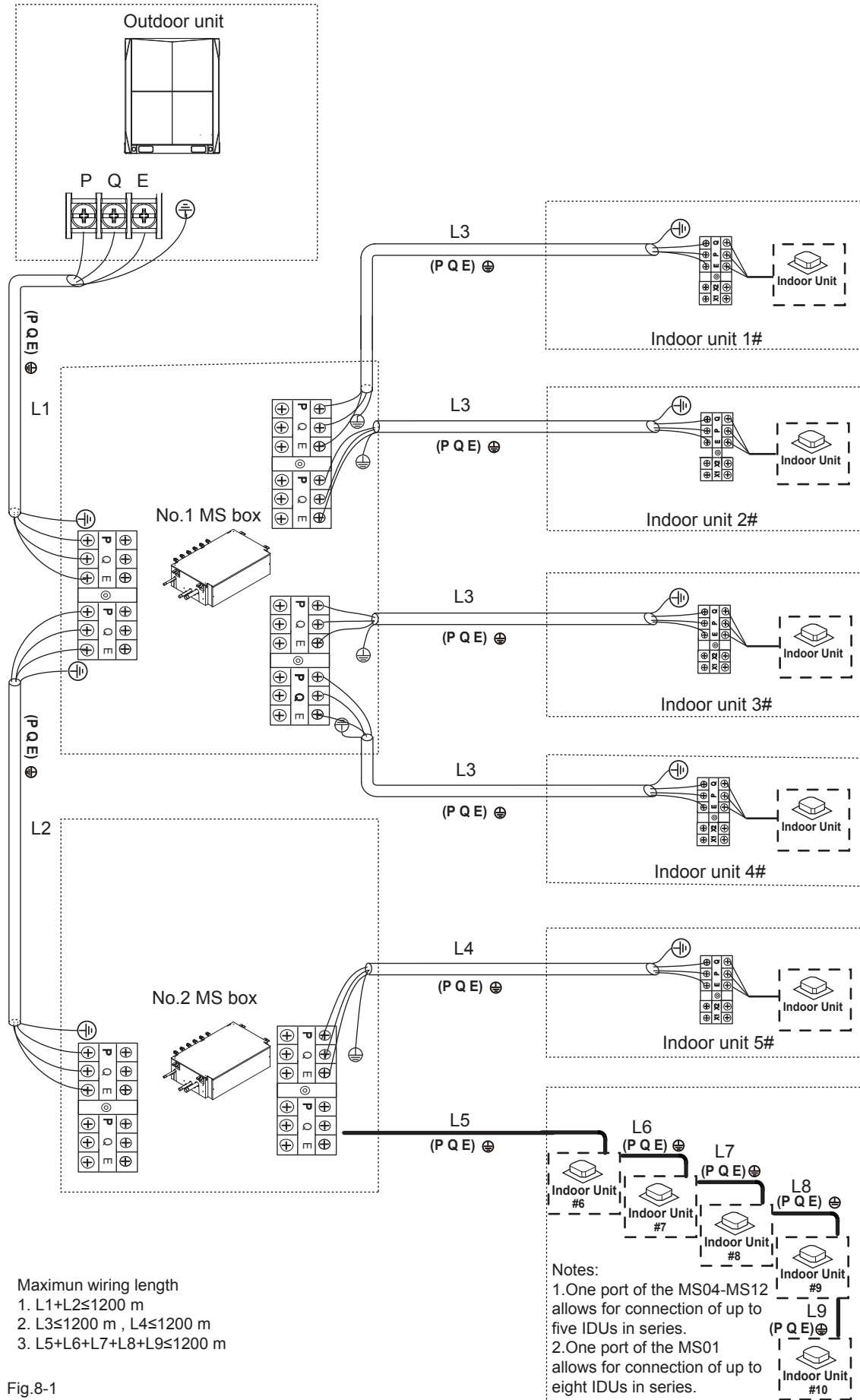

Fig.8-1

8.6 Wiring of piping lines and control wires

Piping & Communication Cable Connection

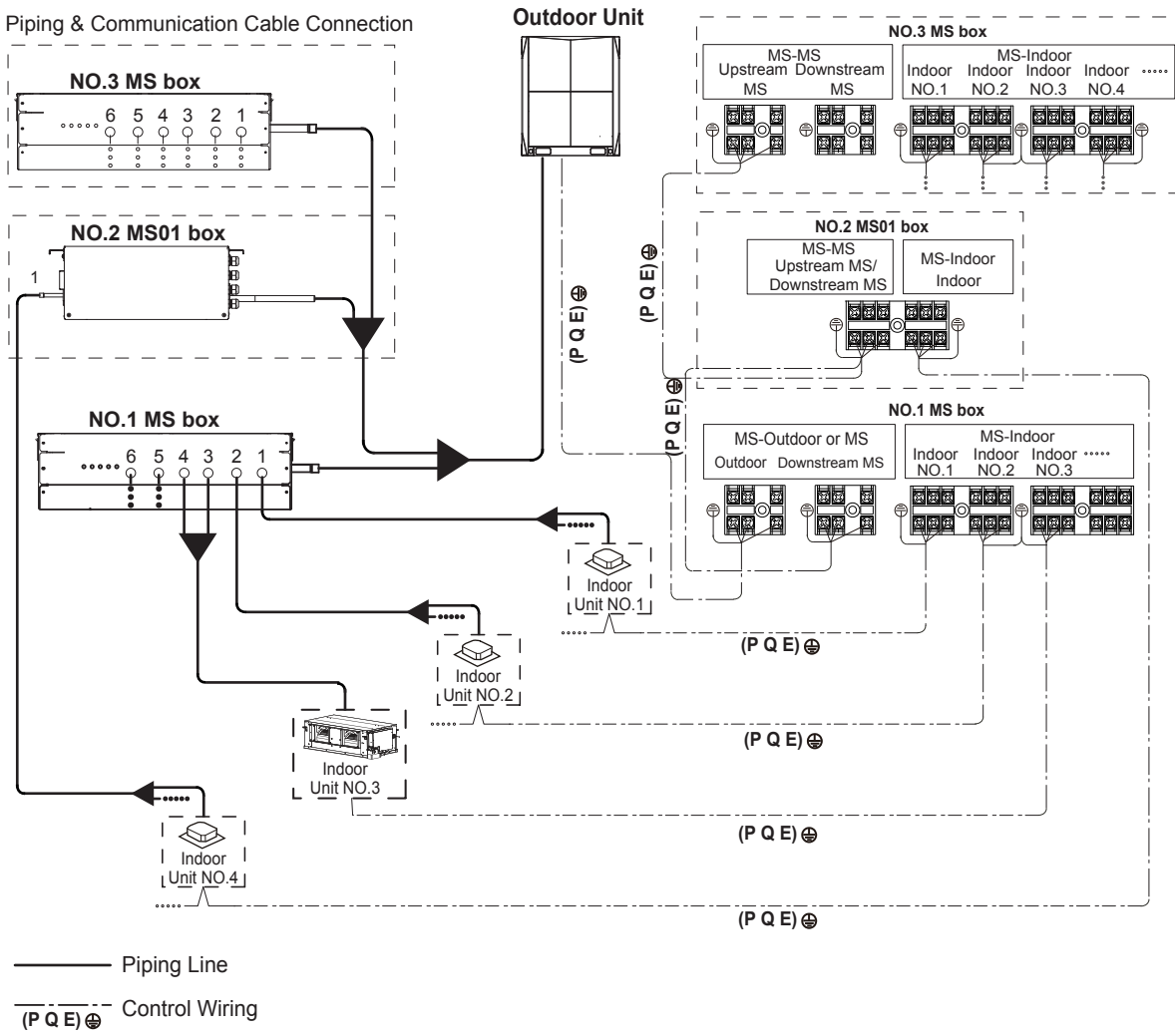

Fig.8-2

NOTE

Indoor control wiring must match the indoor piping connection.

9 INITIAL SETTING



Follow the instructions below to set the DIP switches as necessary.

⚠ WARNING

Electric shock hazard! Before performing work on the unit, be sure to disconnect any power sources which are connected to the unit.

9.1 Definition of DIP switches for the single MS box and refrigerant leakage sensor description

Table 9-1

DIP Switch Code	DIP Switch Settings	Definition of DIP Switches
S1		S1-1 OFF: refrigerant leakage function invalid (default) ON: connected to refrigerant leakage sensor
		S1-2 OFF: dry contact is always closed, and opened when being triggered by refrigerant leakage (default) ON: dry contact is always opened, and closed when being triggered by refrigerant leakage
S2		S2-1 OFF: low temperature cooling function valid (default) ON: low temperature cooling function invalid
		S2-2 Reserved
ENC1		DIP switch for number of refrigerant leakage sensors

Refrigerant leakage sensor connection and settings

a. Cut off power before connect the refrigerant leakage sensor to the corresponding port on the MS main board;

A standard unit does not come with refrigerant leakage sensors, so it must be purchased separately. The user shall confirm that the following conditions are met before purchasing.

1. An independent power supply system is available.
2. The signal output to MS must be a switching signal.
3. Under normal circumstances, MS is connected to the closing signal output by the refrigerant sensor. When Ms detects the opening signal of the refrigerant sensor, it indicates that there is refrigerant gas leakage.
4. The control voltage of output detection signal of the refrigerant sensor is less than 5V.
5. The unit is in compliance with local laws and regulations.

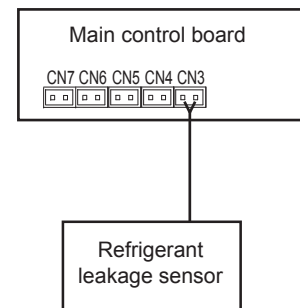

Fig.9-1

b. At most 5 refrigerant leakage sensors are connected to one MS, and the connection port number of refrigerant sensor is CN3 ~ CN7 on the main board.

c. Change ENC1 so that it is consistent with the number of connected refrigerant leakage sensors.

d. S1-1 DIP switch is dialed to "ON" on the left.

(It is advised to record the correspondence between the port number and the actual sensor to facilitate the location of the leakage)

Notes:

When a refrigerant leakage fault is detected, MS spot check displays error code "A1". If refrigerant leakage is treated, press and hold SW2 for 3s to clear the fault.

9.2 Dry contact interface connection

Table 9-2

fan	Fan control port
alarm	Alarm control port

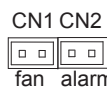

(Current range: 0-1A)

(Voltage range: 0-24VAC/DC)

Notes:

1. For the opening and closing of dry contact, please refer to dial code S1-2 in table 9-1 for setting.
2. When the external exhaust fan or alarm is connected, the overcurrent protection circuit breaker with current 1A shall be connected.

9.3 Definition of DIP switches for the multi MS box

9.3.1 MS PCB number

The address switch[ENC2] is set by the factory, and can't be changed.

Table 9-3

	<p>MS PCB number (Factory setting, can't be changed. 0 means the first PCB, 1 means the second PCB, 2 means the third PCB)</p>
--	--

9.3.2 Setting switch

When two group pipes connect to one IDU, the switch [S1/S2] must be set as follows:

Table 9-4

<p>S1/S2</p> <p>(00 is default)</p>	<p>S1: 11 means synchronous control for 2 ports (First PCB is port 1 and 2, Second PCB is port 5 and 6, third PCB is port 9 and 10)</p> <p>S2: 11 means synchronous control for 2 ports (First PCB is port 3 and 4, Second PCB is port 7 and 8, third PCB is port 11 and 12)</p>
-------------------------------------	--

⚠ CAUTION

The switch must be either 00 or 11.

The indoor unit communication cable is connected to one of the two indoor unit PQE ports of MS box.

9.4 Setting and querying the MS box address

The MS unit can perform automatic addressing based on ODU instructions, or users can set MS address manually.

How to set:

Press and hold SW3 for 3s to open the page. The page displays -1+MS address, with -1 indicating the MS address. When the MS address flashes, press SW1 and SW2 to set the MS address within the range of 0 - 63. After that, press and hold SW3 for 3s to confirm the settings. If no operation is made within 30s, the page will automatically close and your changes will not be saved.

10 CHARGING ADDITIONAL REFRIGERANT

Follow the instructions in the installation manual that came with the outdoor unit to charge additional refrigerant.

11 QUERY INSTRUCTIONS

11.1 SW1/SW2 query instructions

Spot check list for general information.

Press SW1 and SW2 to forward and backward to spot check the MS box data. After 1s shows the no., the display will automatically show the data. For example, to check the outdoor operation mode, press SW1/SW2 to show -02, then stop and wait for 1s, and the display will show the number of the current outdoor operation mode.

MS01:

Table 11-1

Displayed	Description	Note
Default	Online IDU Qty & Refrigerant leakage sensor Qty	
--01	Running IDU Qty	
--02	System Operation Mode	0-OFF; 2-Cooling Only; 3-Heating Only; 5-Mix Cooling Mode; 6-Mix Heating Mode
--03	High pressure (MPa)	
--04	Low pressure (MPa)	
--05	Subcooler outlet temperature	
--06	Subcooler inlet temperature	
--07	EEV Throttle Position	
--08	Software Version	
--09	MS Address	
--10	EBV A Throttle Position	Actual value/10
--11	EBV B Throttle Position	Actual value/10
--12	EBV C Throttle Position	Actual value/10
--13	Port No. for refrigerant leakage alarm	If there are multiple alarms at the same time, only the minimum port number is displayed
--14	Number of ports for refrigerant leakage alarm	
--15	Min (T2, T2B) of cooling operation IDU under the MS	If there is no cooling operation of the indoor unit, the digital display "--"

MS04 - MS12:

Table 11-2

Displayed	Description	Note
Default	Online IDU Qty	
--01	Running IDU Qty	
--02	System Operation Mode	0-OFF; 2-Cooling Only; 3-Heating Only; 5-Mix Cooling Mode; 6-Mix Heating Mode
--03	High pressure (MPa)	
--04	Low pressure (MPa)	
--05	Subcooler outlet temperature	
--06	Subcooler inlet temperature	
--07	EEV A Throttle Position	
--08	Software Version	
--09	MS Address	
--10	--	--

SW3/SW4 query instructions

Spot check list for indoor address information.

Press SW3 and SW4 to move forward and backward and spot check the indoor address under the specific port of the MS box.

Table 11-3

Displayed	Description	Note
1.**	1 means the port number	Not applicable to the single MS box
2.**	2 means the port number	
3.**	3 means the port number	
4.**	4 means the port number	

** means the indoor address, if there is more than one indoor unit under the port, the addresses will show individually in a 2s interval.

-- means the end of the indoor address list.

11.2 Troubleshooting

Malfunction display of MS units DSP

Error code table for single MS box

Table 11-4

Error code	Content	Remarks	Manual restart required
E2	Communication failure between MS and master outdoor unit.	The indoor unit display board or remote control connected under this MS displays "F8" fault code	No
E3	Malfunction of subcooler outlet thermistor(T1C1)	The indoor unit display board or remote control connected under this MS displays "F8" fault code	No
E4	Malfunction of subcooler inlet thermistor(T2C2)	The indoor unit display board or remote control connected under this MS displays "F8" fault code	No
E7	EEPROM error	The indoor unit display board or remote control connected under this MS displays "F8" fault code	Yes
FE	MS has no address when first powered on	The indoor unit display board or remote control connected under this MS displays "F8" fault code	No
F6	Electronic ball valve connection failure	The indoor unit display board or remote control connected under this MS displays "F8" fault code	Yes
F7	Main power off	The indoor unit display board or remote control connected under this MS displays "F8" fault code	No
F9	Overload error	The indoor unit display board or remote control connected under this MS displays "F8" fault code	Yes
A1	Refrigerant leakage protection or ENC1 DIP switch value >5	All outdoor units, indoor units and controllers display "A1"	Yes

Error code table for multi MS box

Table 11-5

Error code	Content	Remarks	Manualre-start required
E2	Communication failure between MS and master outdoor unit.	The indoor unit display board or remote control connected under this MS displays "F8" fault code	No
E3	Malfunction of subcooler outlet thermistor(T1C1)	The indoor unit display board or remote control connected under this MS displays "F8" fault code	No
E4	Malfunction of subcooler inlet thermistor(T2C2)	The indoor unit display board or remote control connected under this MS displays "F8" fault code	No
E7	EEPROM error	The indoor unit display board or remote control connected under this MS displays "F8" fault code	Yes
FE	MS has no address when first powered on	The indoor unit display board or remote control connected under this MS displays "F8" fault code	No
LL	S1+S2 dialing setting error	The indoor unit display board or remote control connected under this MS displays "F8" fault code	Yes
H0	Communication between master and slave control boards failed	The indoor unit display board or remote control connected under this MS displays "F8" fault code	No

